

CONFIDENTIAL RECORDS PURSUANT TO 1 M.R.S.A. § 405 (6) (F)

4 PUBLIC COMMENT(S) ON ANY ITEM(S)

5 ADJOURN



October 15,2021

Major Nathan Thayer
Jail Superintendent, York County Sheriffs Office
1 Layman Way, Alfred, Maine 04002
Ph:207-459-2203Email: ncthayer@yorkcountymaine.gov

Quote# 2021-10-17

Please see the quotation below for the Tek84 Intercept Whole Body Scanner.

Table with 5 columns: Qty, Part Number, Description, MSRP, Ext. Price. Contains 4 rows of items including the main scanner unit, shipping, training, and warranty.

Special Luminary Site Pricing Total \$159,000.00

Extended Warranty \$7,500.00 after year 2 TBD Quote Expiration: Jan 15, 2022

By execution of this Agreement by an authorized signature, the Customer agrees to purchase the Products specified subject to the terms and conditions set forth in the Agreement and subject to Tek84 Terms and Conditions available at www.Tek84.com

DAP: Destination- Alfred ME
Terms: Net 30 Days
Taxes: ADD as Necessary at or provide exemption certificate

Accepted By: Printed Name and Title:
Authorized Signature:
Date:
Tek84: Printed Name and Title:
Authorized Signature:
Date:

13495 Gregg Street
Poway, CA 92064
Phone: 858-676-5382
www.Tek84.com



Intercept

Full Body Scanner

Quick Start Guide

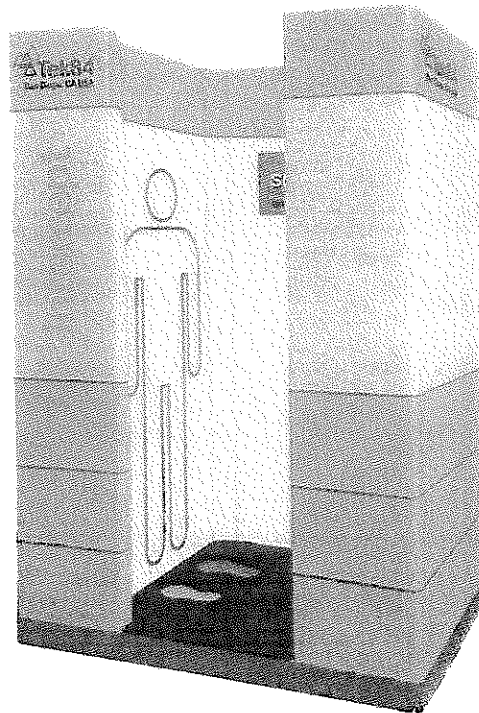

Table of Contents

1	POWERING UP	1
1.1	KEY SWITCH.....	1
1.2	LOGGING IN.....	1
1.3	PREPARING THE SCANNER.....	2
2	HOW TO SCAN SUBJECTS	4
2.1	ENTERING SUBJECT INFORMATION.....	4
2.1.1	<i>Add New Subject from Home Screen</i>	4
2.1.2	<i>Add New Subject from Find Subject Screen</i>	6
2.1.3	<i>No ID Scan</i>	6
2.1.4	<i>Find Existing Subject from Home Screen</i>	7
2.1.5	<i>Find Existing Subject from Find Subject Screen</i>	8
2.2	SELECTING DOSE LEVEL.....	8
2.3	TAKING SUBJECT'S PHOTO.....	9
2.4	SUBJECT POSITIONING.....	10
2.5	PERFORMING THE SCAN.....	10
2.6	STOP SCAN.....	10
3	REVIEWING THE SCAN	11
3.1	SCANID.....	11
3.2	ADJUSTING THE IMAGE.....	11
3.2.1	<i>Brightness / Contrast</i>	12
3.2.2	<i>Invert / Reset</i>	12
3.2.3	<i>Zoom</i>	12
3.3	CHANGE IMAGE VIEWS.....	13
3.4	SCAN RESULTS TOOLBAR.....	13
3.4.1	<i>Subject Information</i>	14
3.4.2	<i>Show by ScanID</i>	14
3.4.3	<i>Show Last Scan</i>	14
3.4.4	<i>Mark As Suspect</i>	14
3.4.5	<i>Compare Images</i>	14
3.4.6	<i>Rescan Subject</i>	17
4	HOW TO VIEW SUBJECTS	18
4.1	SUBJECT SEARCH TOOLS.....	18
4.2	VIEW ALL SUBJECT SCANS.....	19
4.3	EDITING SUBJECT NAME.....	19
5	LOGGING OUT	20
5.1	LOGGING OUT.....	20
5.2	POWERING OFF.....	20

List of Figures

FIGURE 1: CONTROL PANEL.....	1
FIGURE 2: LOGIN SCREEN	2
FIGURE 3: PREPARE SCANNER BUTTONS	3
FIGURE 4: HOME SCREEN	3
FIGURE 5: SUBJECT INFORMATION BOX	4
FIGURE 6: ENTER SUBJECT ID PROMPT	4
FIGURE 7: NO SUBJECT FOUND MESSAGE.....	5
FIGURE 8: ENTER NEW SUBJECT SCREEN	5
FIGURE 9: ADD SUBJECT (FIND SUBJECT SCREEN).....	6
FIGURE 10: SEARCH BY LAST NAME (HOME SCREEN).....	7
FIGURE 11: SUBJECT RECALLED (HOME SCREEN)	8
FIGURE 12: FIND SUBJECT SEARCH	8
FIGURE 13: SCAN DOSE LEVELS	9
FIGURE 14: TAKE SUBJECT PHOTO	9
FIGURE 15: SUBJECT PHOTO CAPTURED	9
FIGURE 16: SCAN BUTTONS.....	10
FIGURE 17: SCAN RESULTS SCREEN	11
FIGURE 18: IMAGE DISPLAY CONTROLS	12
FIGURE 19: HiRes, 3D ENHANCED AND DETAIL IMAGE VIEWS (L TO R)	13
FIGURE 20: SCAN RESULTS TOOLBAR.....	13
FIGURE 21: COMPARISON OPTION MENU	15
FIGURE 22: COMPARE SCAN TO CURRENT SUBJECT IMAGES	16
FIGURE 23: COMPARE IMAGES SCREEN	16
FIGURE 24: RESCAN SUBJECT RECALLED	17
FIGURE 25: FIND SUBJECT SCREEN	18
FIGURE 26: SUBJECT DATA BOX.....	19
FIGURE 27: EDIT SUBJECT NAME PROMPT.....	19

1 POWERING UP

1.1 Key Switch

To power up:

1. Insert the key in the Control Panel (Figure 1, Item 5).
2. Turn the key 90° clockwise. When the key is in the horizontal position the system is on.
3. The blue power light indicates power is on (Figure 1, Item 4).

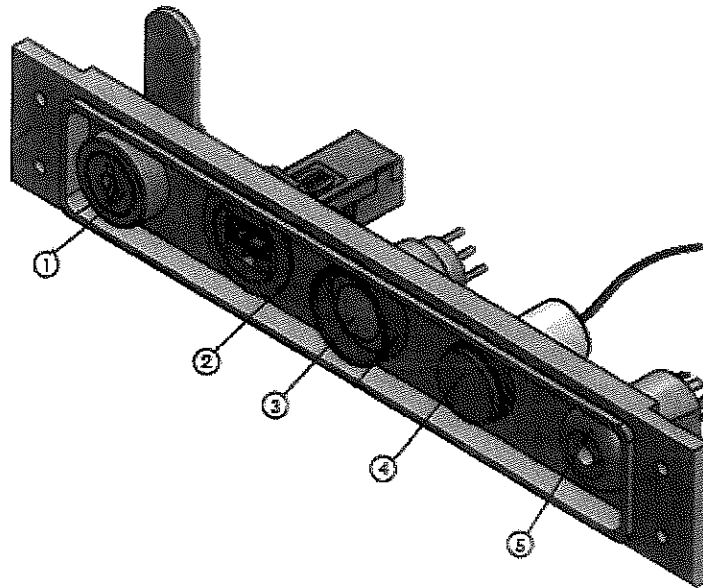

Figure 1: Control Panel

1.2 Logging In

The Login Screen displays two (2) minutes after powering up (Figure 2). The touchscreen technology can recognize input from a gloved finger.

A valid User ID and Password or a PIN is required to log in. There are two (2) ways to log in to the system:

- User ID and Password
- PIN

Choose a method of login and proceed. After a successful login, the Home Screen displays (Figure 4).

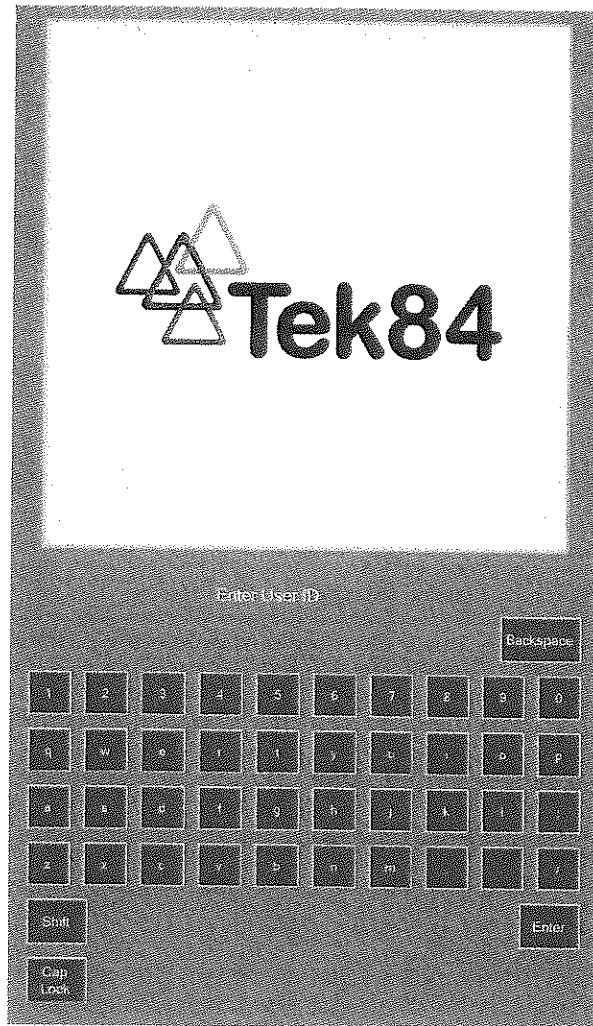

Figure 2: Login Screen

1.3 Preparing the Scanner

If Intercept was restarted or turned on from off, **Prepare Scanner** buttons appear instead of the Home Screen after logging in. The final step of the boot-up process is **Prepare Scanner** (Figure 5).

Only one (1) button lights up at a time. Press the left sided **Prepare Scanner** button. Then, the right sided **Prepare Scanner** button lights up. Press the buttons from left to right.

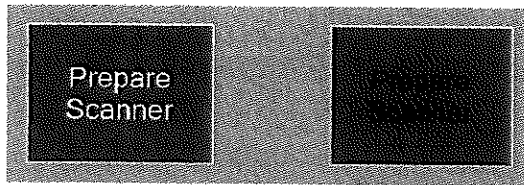

Figure 3: Prepare Scanner Buttons

When complete the following happens and Intercept is now ready to scan:

1. The system loads the Home Screen (Figure 4)
2. **Prepare Scanner** buttons change to **Scan** buttons.

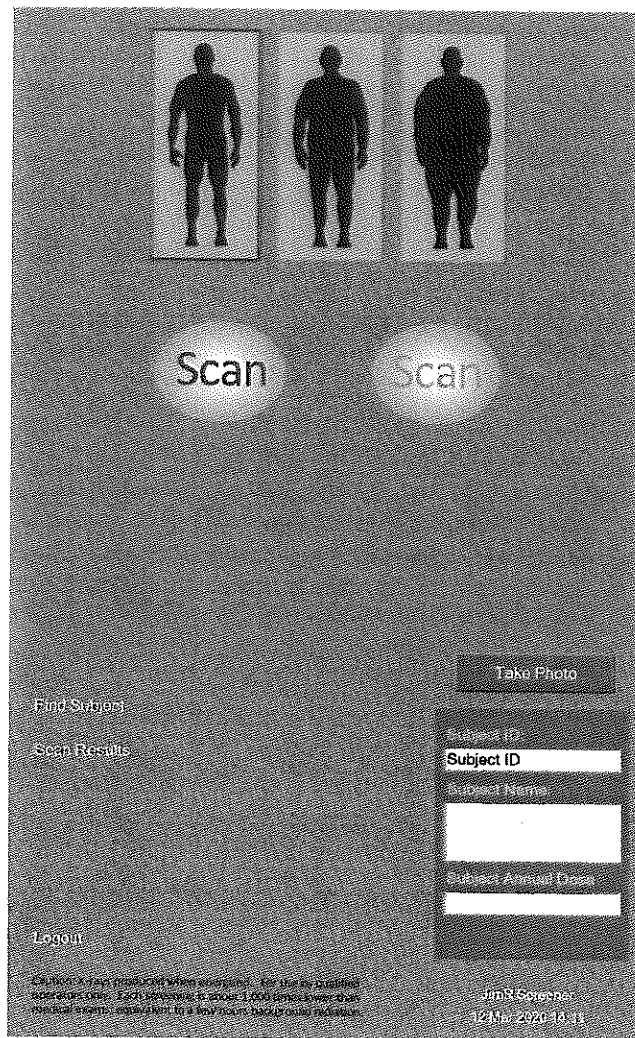

Figure 4: Home Screen

2 HOW TO SCAN SUBJECTS

2.1 Entering Subject Information

Enter the subject's information on the Home Screen (Figure 5).

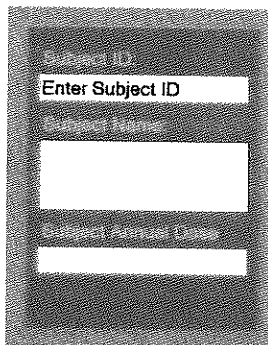

Figure 5: Subject Information Box

If the subject is new, add the subject's information to the system.

2.1.1 Add New Subject from Home Screen

To add a new subject from the Home Screen, select the **Subject ID** box (Figure 5). This brings up the on-screen keyboard (Figure 8). Enter the Subject ID and press **Enter**.

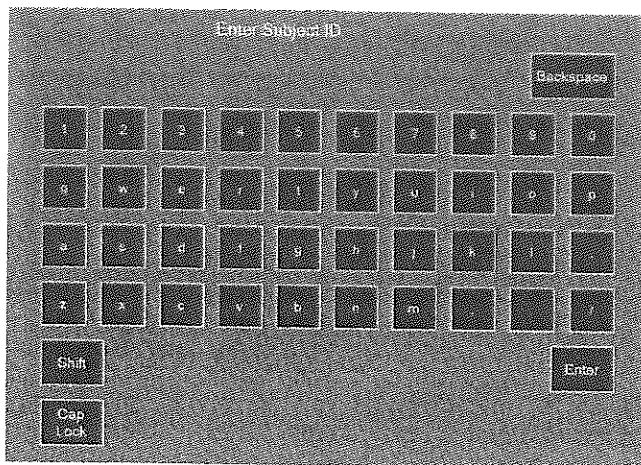

Figure 6: Enter Subject ID Prompt

If a new Subject ID is entered, the system displays a pop-up message that the subject was not found and asks if you want to add the subject (Figure 7).

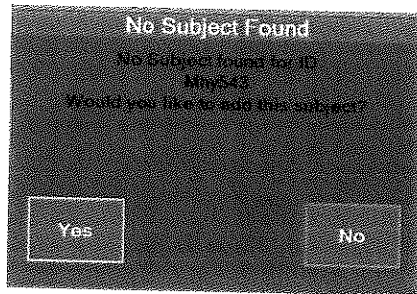

Figure 7: No Subject Found Message

Select **Yes** to add the subject. This loads the New Subject Screen that asks for the subject's last, first, and middle name (Figure 8). Enter the required information and press **Save** or **Enter**.

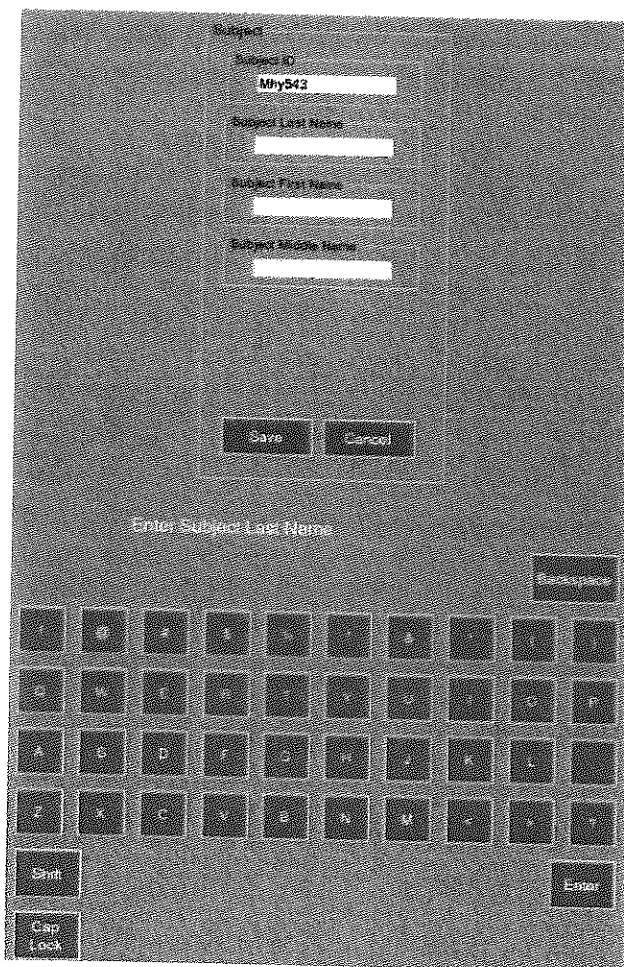
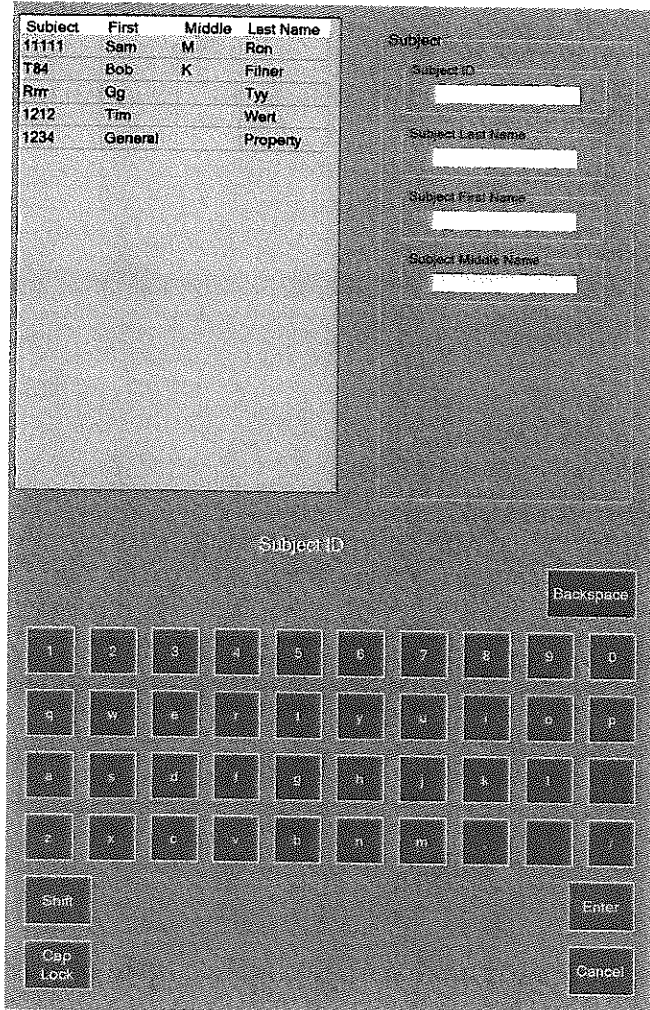

Figure 8: Enter New Subject Screen

The new subject is added to the system and the screen returns to the Home Screen (Figure 4).

2.1.2 Add New Subject from Find Subject Screen

Alternatively, add a new subject from the Find Subject Screen (Figure 9). Select **Find Subject** from the Home Screen. Then, select **Add Subject**. This opens a New Subject Screen that prompts for the subject's ID, last name, first name, and middle name. Enter the required information as prompted and press **Save** or **Enter** when done.



Subject	First	Middle	Last Name
11111	Sam	M	Ron
T84	Bob	K	Fisher
Rm	Gg		Tyy
1212	Tim		Wert
1234	General		Property

Subject:

Subject ID

Subject Last Name

Subject First Name

Subject Middle Name

Subject ID

Backspace

1	2	3	4	5	6	7	8	9	0
q	w	e	r	t	y	u	i	o	p
a	s	d	f	g	h	j	k	l	
z	x	c	v	b	n	m			/

Shift

Enter

Cap Lock

Cancel

Figure 9: Add Subject (Find Subject Screen)

The new subject appears in the Subject List Box on the left side once added (Figure 9).

2.1.3 No ID Scan

If the subject is scanned without being added to the system, the scan is categorized as **No ID**.

If you press **No** to the No Subject Found Message (Figure 7) and do not add the new subject to the system, the screen returns to the Home Screen. A scan performed without information in the Subject Information Box will have no associated identification. Scans without Subject IDs are categorized **No ID** in the database and assigned "-1" for the Subject ID.

2.1.4 Find Existing Subject from Home Screen

If the subject is already in the system, find the subject by either the Subject ID or Subject Name. Select the Subject ID or Subject Name field in the Subject Information Box on the Home Screen (Figure 5).

- To search by Subject ID - Enter the Subject ID in the on-screen keyboard. If the Subject ID is already in the system, the matching Subject ID imports into the Subject Information Box.
- To search by Subject Name - Enter at least two (2) letters of the subject's last name in the on-screen keyboard. The list of subjects that match the search parameters displays on the screen (Figure 10).

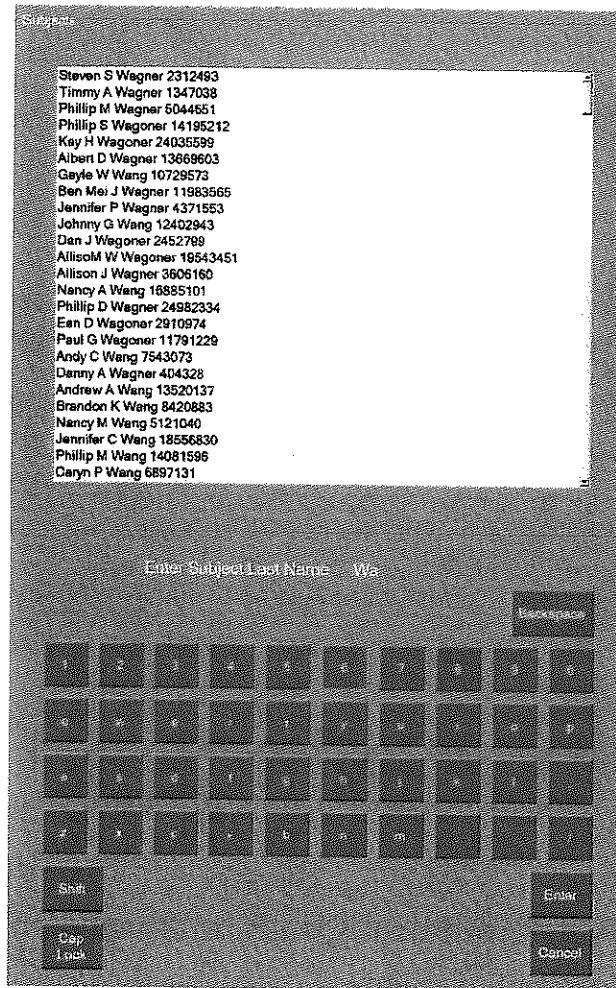

Figure 10: Search by Last Name (Home Screen)

Select the subject from the list. The selected subject's information imports into the Subject Information Box on the Home Screen (Figure 11).

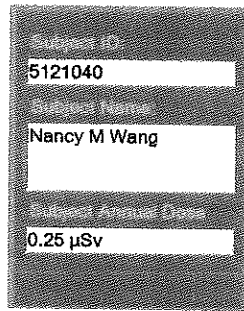
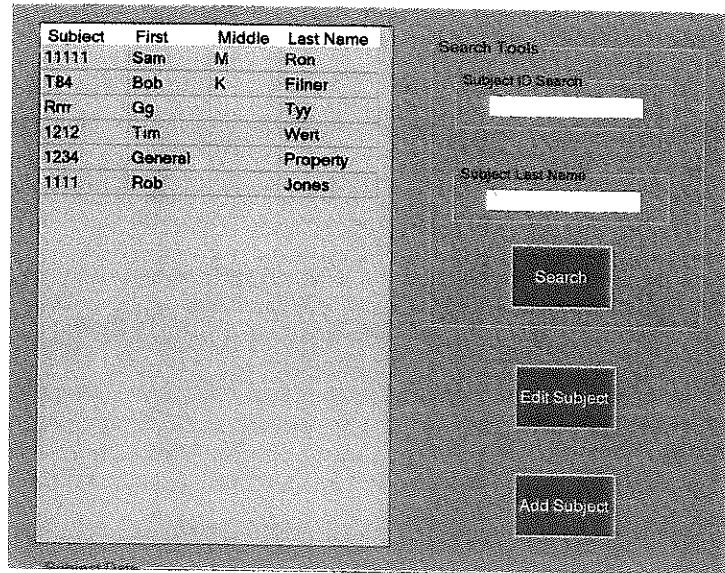

Figure 11: Subject Recalled (Home Screen)

2.1.5 Find Existing Subject from Find Subject Screen

If the subject is already in the system, alternatively find the subject from the Find Subject Screen. Select **Find Subject** on the Home Screen. See the Search Tools in the Find Subject Screen (Figure 12).



Subject	First	Middle	Last Name
11111	Sam	M	Ron
T84	Bob	K	Filmer
Rrr	Gg		Tyy
1212	Tim		Wert
1234	General		Property
1111	Rob		Jones

Figure 12: Find Subject Search

Select **Subject ID Search** or **Subject Last Name**. To search by Subject Last Name, enter at least two (2) letters of the last name then press **Enter** or **Search**. Search results that match the search parameters display in the table. Highlight the desired subject and select **Return**. The selected subject's information imports into the Subject Information Box on the Home Screen (Figure 11).

2.2 Selecting Dose Level

Select the appropriate Dose Level for the subject before the scan (Figure 13).

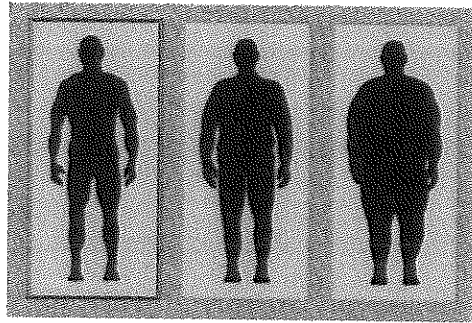

Figure 13: Scan Dose Levels

2.3 Taking Subject's Photo

Instruct the subject to face the camera located under the Internal Monitor. Press **Take Photo** on the Home Screen (Figure 14).

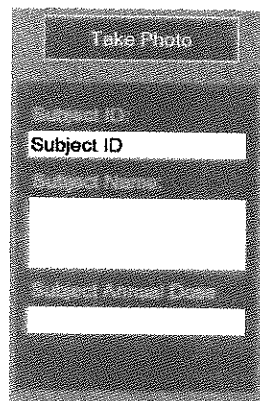

Figure 14: Take Subject Photo

The system automatically zooms in on the subject's face, crops the photo, and displays the photo on above the **Take Photo** button (Figure 15).

The subject's photo stays on the Home Screen for two (2) minutes unless you press **Clear Photo** to retake the photo or you perform the scan. Scan the subject within two (2) minutes of the photo capture to attach the photo to the scan. Otherwise, the scan does not include the subject's photo.

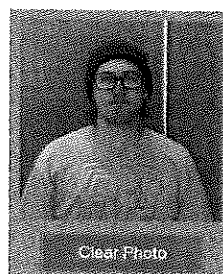

Figure 15: Subject Photo Captured

2.4 Subject Positioning

Instruct the subject to enter the scanner and stand on the footmarks a few inches from the wall with hands to the sides.

2.5 Performing the Scan

There are two (2) **Scan** buttons in the middle of the Home Screen (Figure 16).

Only one (1) **Scan** button lights up at a time from left to right. Press the left sided **Scan** button first. Then, the right sided **Scan** button lights up. Press the right sided **Scan** button within five (5) seconds of the left side. Press the two (2) **Scan** buttons from left to right to perform the scan.

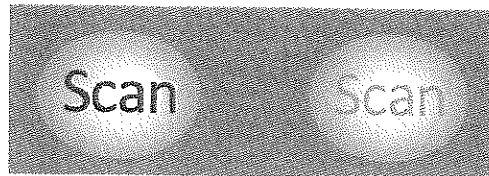

Figure 16: Scan Buttons

2.6 Stop Scan

If necessary, you can stop the scan in progress at any time during the four (4) second duration. **Stop Scan** button is located on the control panel on the operator kiosk (Figure 1, Item 3).

A Stop Scan message appears on the screen and loads a partially scanned image.

3 REVIEWING THE SCAN

After the scan is over, the scan image appears on the Scan Results Screen (Figure 17). Review the image using the controls described below.

3.1 ScanID

At the top of the image is the ScanID. The system generates a unique ScanID for each scan: the first three (3) characters are the Site Code followed by a number that increases sequentially.

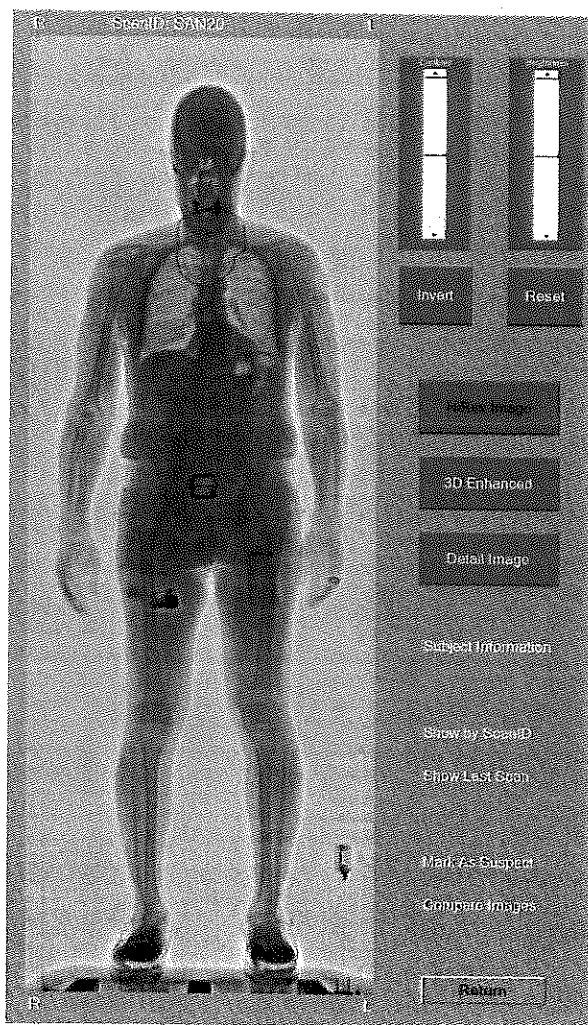

Figure 17: Scan Results Screen

3.2 Adjusting the Image

Review the scan image using the Image Display Controls on the Scan Results Screen (Figure 18).

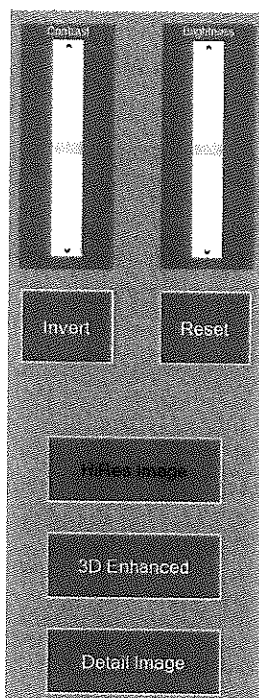

Figure 18: Image Display Controls

3.2.1 Brightness / Contrast

There are four (4) image display controls available to modify the colorization of pixels.

Use the two (2) scrollbars at the top to adjust the image **Contrast** and **Brightness**: scroll up or press the upward arrow to increase or scroll down or press the downward arrow to decrease.

3.2.2 Invert / Reset

Select **Invert** to reverse the colors of the image: white reverses to black, light reverses to dark and vice versa. This is done by inverting all pixel values in the image by changing dark pixels to lighter values and lighter pixels to darker values.

Select **Reset** to return the image brightness and contrast display to the default values. All image adjustments reset automatically when you perform a new scan or log out.

3.2.3 Zoom

Tap anywhere on the image to zoom in on the image. The system magnifies the selected area. There is only one (1) zoom level. Touch the screen again to zoom out and return to the original view.

3.3 Change Image Views

There are three (3) different ways to view the image: **HiRes**, **3D Enhanced**, and **Detail Image** (Figure 19).

The default image view is **HiRes** (Figure 17). Select **3D Enhanced** or **Detail Image** to review the image in different views (Figure 19).

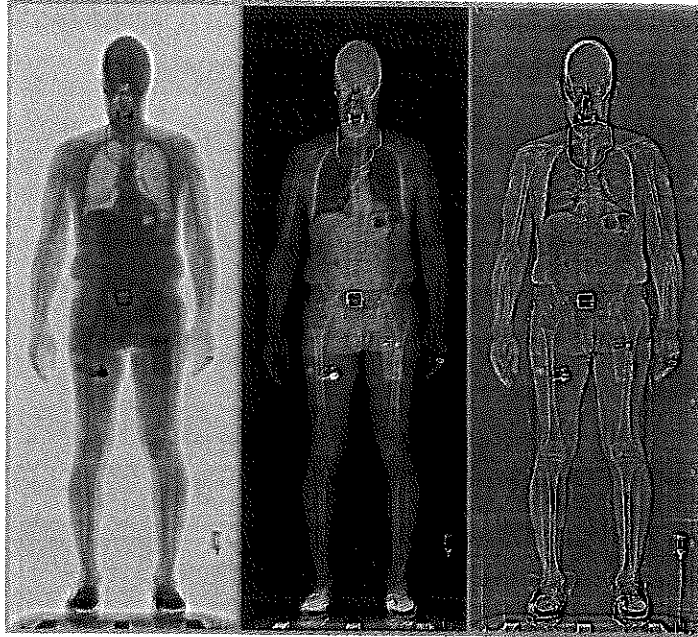

Figure 19: HiRes, 3D Enhanced and Detail Image Views (L to R)

3.4 Scan Results Toolbar

There are additional buttons on the Scan Results Screen in the Scan Results Toolbar (Figure 20).

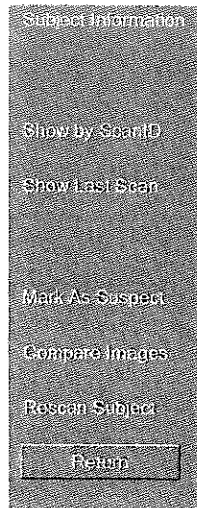

Figure 20: Scan Results Toolbar

3.4.1 Subject Information

Select **Subject Information** to view the following information about the scanned subject: Subject ID, Subject Name, Scan Date and Time, Scan Dose.

3.4.2 Show by ScanID

Select **Show by ScanID** to retrieve any scan by ScanID number.

3.4.3 Show Last Scan

Select **Show Last Scan** to retrieve the most recent scan image.

3.4.4 Mark As Suspect

Select **Mark as Suspect** to flag a scan image as Suspect for any reason.

3.4.5 Compare Images

Compare any image to another existing scan image.

Select **Compare Images** to choose the image for comparison. The Comparison Option Menu displays to the right of the current image (Figure 21). Compare the current image to any existing image in any of three (3) ways:

- **Current Subject Images** - Compare to the current subject's previous scan (Figure 22). Select the **Current Subject Images** tab to select from any of the current subject's previous scans.
- **Library Images** - Compare to an image added to the Library (Figure 21). Select the **Library Images** tab to select the desired Library Image for comparison.
- **Search By ScanID** - Compare to any other scan by ScanID. Select **Search by ScanID** to search for a comparison image by ScanID number (Figure 21).

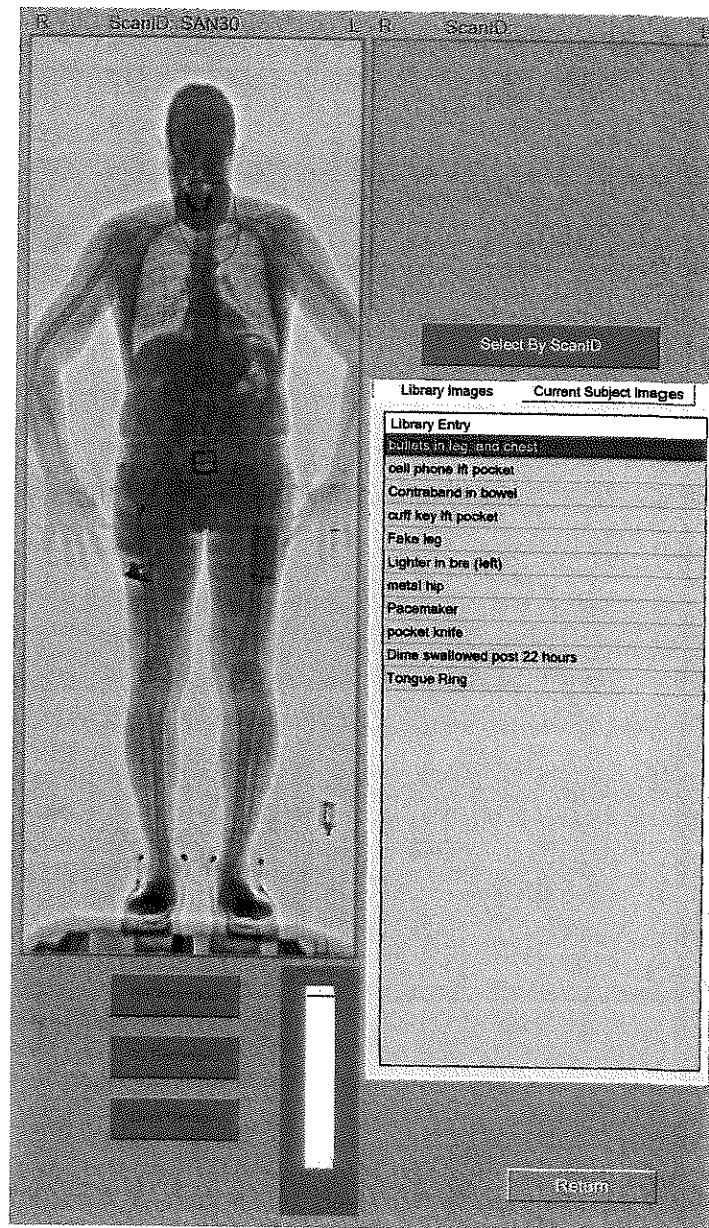

Figure 21: Comparison Option Menu

When you select the image for comparison, the two (2) images appear side by side (Figure 23). The same Image Display Controls in Section 3.2, Adjusting the Image, and Section 3.3, Change Image Views, are also available on the Compare Images Screen (Figure 23).

Use the Image Display Controls to compare and review the images. Both images are connected by default indicated by the blue border around both images. The Image Display Controls affect both images when connected.

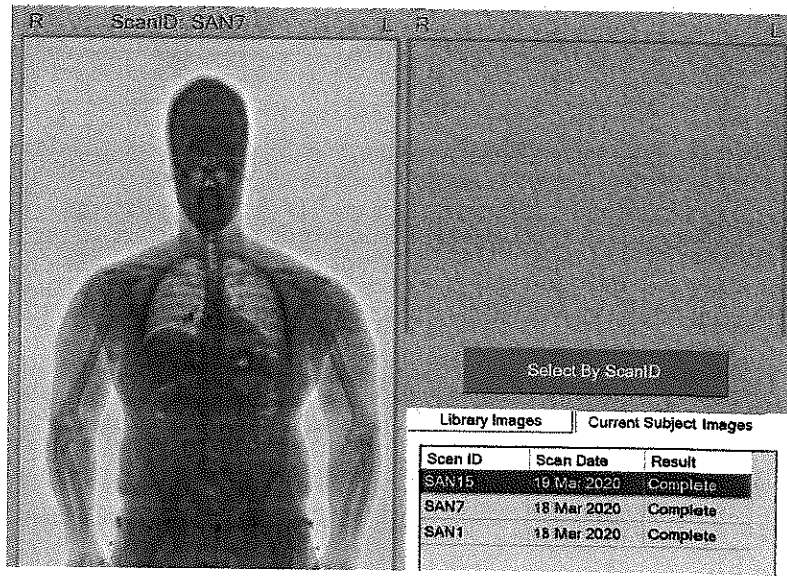

Figure 22: Compare Scan to Current Subject Images

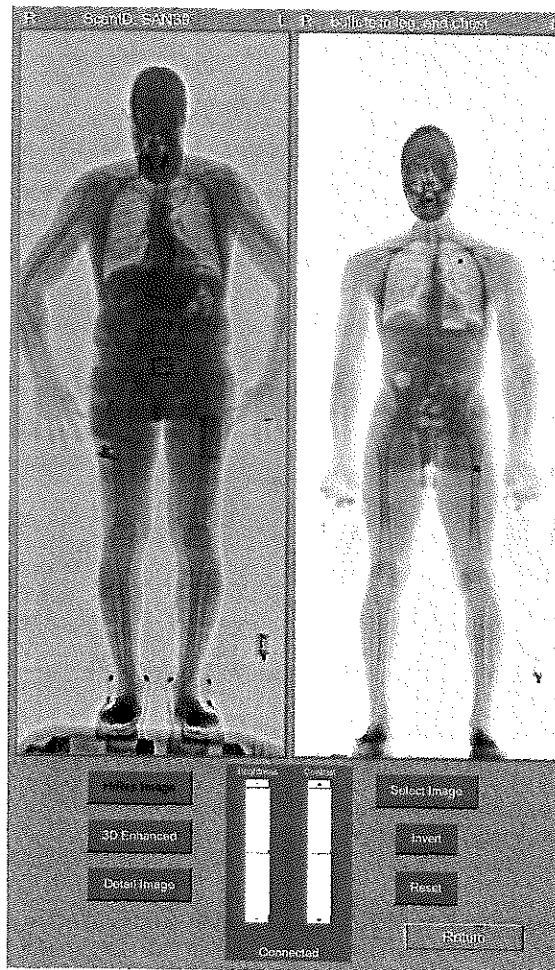

Figure 23: Compare Images Screen

To disconnect the images, press **Connected** at the bottom of the screen. This disconnects the images, removes the blue border around the comparison image on the right, and leaves the blue border around the current image on the left. Any adjustments using the Image Display Controls only affects the image highlighted with the blue border. To switch to the comparison image on the right, select the right image.

The blue border highlights the image to indicate it is selected.

To re-connect the two images, press **Connect**.

3.4.6 Rescan Subject

If you need to re-scan the same subject for any reason, it can be done quickly with the re-scan feature. This feature is only available for five (5) minutes on the Scan Results Screen immediately after a scan has been performed. The re-scan feature disappears after five (5) minutes. If you exit the Scan Results Screen displaying the recently scanned image, the re-scan feature also disappears.

Select **Rescan Subject** after the initial scan within the five (5) minute window. Selecting this feature returns the screen to the Home Screen and populates the Subject Information Box and the Subject's photo with the same information used for the last performed scan (Figure 27).

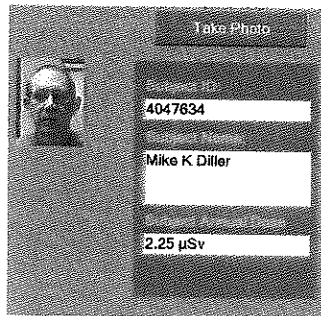

Figure 24: Rescan Subject Recalled

4 HOW TO VIEW SUBJECTS

To view all subjects in the system, select **Find Subject** on the Home Screen.

4.1 Subject Search Tools

Use the Subject Search Tools on the Find Subject Screen to find a subject in the system (Figure 25).

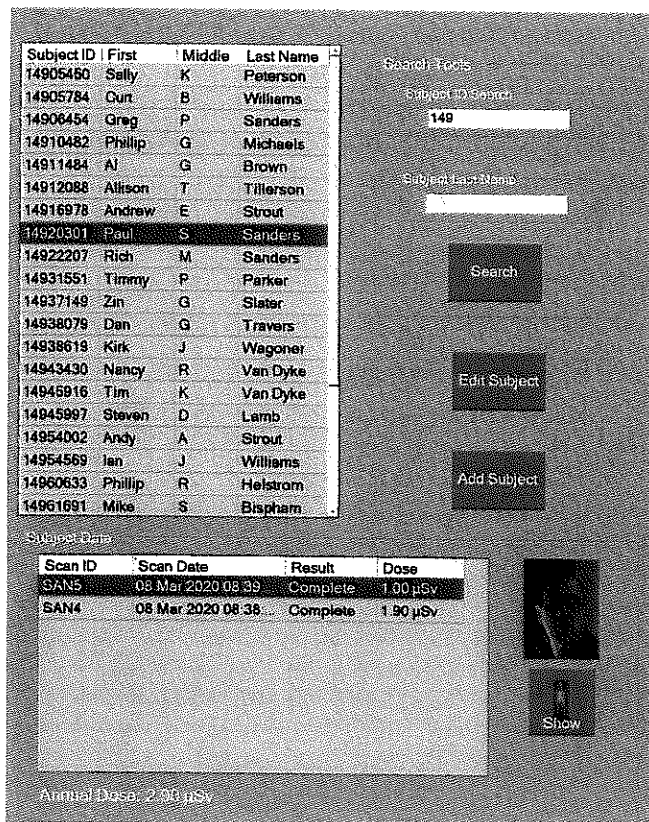

Figure 25: Find Subject Screen

The search function here works the same way as the search function described in Section 2.1.4, Finding Existing Subject from Home Screen and Section 2.1.5, Finding Existing Subject from Find Subject Screen. See the sections for reference.

If you press **Search** with empty search parameters, the system loads all existing subjects.

Specify the search parameters with the Search Tools (Figure 25). Select **Subject ID Search** and enter the Subject ID or select **Subject Last Name** and enter at least the first two (2) characters of the subject's last name. Press **Search**. The system displays subjects that meet the search criteria on the Subject List on the left.

4.2 View All Subject Scans

Select the desired subject from the Subject List. The Subject Data box below shows all previous scans belonging to that subject. The data includes: Scan ID, Scan Date, Scan Time, Result and the Annual Dose (Figure 26).

To view a scan, select the Scan ID. If a photo was taken with the scan, the subject's photo appears to the right. Press **Show** to view the image on the Scan Results Screen.

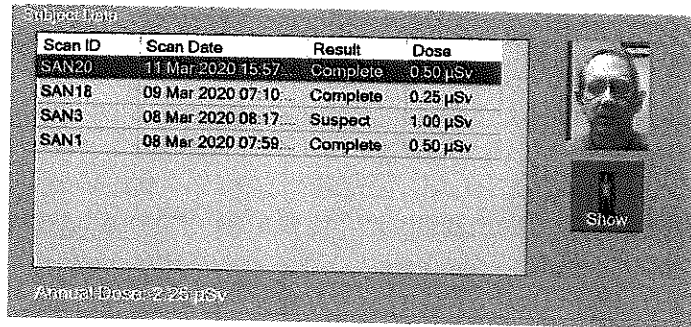

Scan ID	Scan Date	Result	Dose
SAN20	11 Mar 2020 15:57	Complete	0.50 µSv
SAN18	09 Mar 2020 07:10	Complete	0.25 µSv
SAN3	08 Mar 2020 08:17	Suspect	1.00 µSv
SAN1	08 Mar 2020 07:59	Complete	0.50 µSv

Annual Dose: 2.25 µSv

Figure 26: Subject Data Box

4.3 Editing Subject Name

You can change the subject's name. **Edit Subject** refers to Subject Name. Search for the subject to edit with the Search Tools. Select the subject from the Subject List. Press **Edit Subject**

The on-screen keyboard appears and retrieves the subject's first, last and middle name. To change a field, press **Backspace**, enter the correct name and press **Enter** (Figure 27). To keep the field the same, press **Enter** to proceed to the next name field.

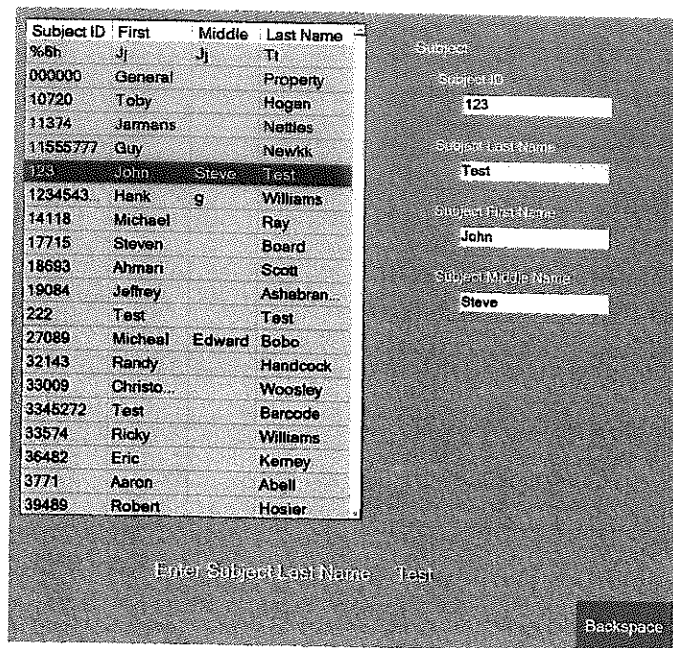

Subject ID	First	Middle	Last Name
%6h	Jj	Jj	Tt
000000	General		Property
10720	Toby		Hogan
11374	Jarmens		Netties
11555777	Guy		Newkk
123	John	Steve	Test
1234543	Hank	g	Williams
14118	Michael		Ray
17715	Steven		Board
18693	Ahman		Scott
19084	Jeffrey		Ashebran...
222	Test		Test
27089	Michael	Edward	Bobo
32143	Randy		Handcock
33009	Christo...		Woosley
3345272	Test		Barcode
33574	Ricky		Williams
36482	Eric		Kemey
3771	Aaron		Abell
39489	Robert		Hosier

Subject ID: 123
 Subject Last Name: Test
 Subject First Name: John
 Subject Middle Name: Steve

Enter Subject Last Name Test
 Backspace

Figure 27: Edit Subject Name Prompt

5 LOGGING OUT

5.1 Logging Out

Log out when done scanning.

The **Logout** button is on the bottom left corner of most screens. If the **Logout** button is unavailable, press the **Return** button to return to a previous screen where the **Logout** button is available.

5.2 Powering Off

Intercept can be left on for hours or days as needed. To turn the power off, turn the key in the key switch 90° counterclockwise to a vertical orientation.



October 15, 2021

Major Nathan Thayer
 Jail Superintendent, York County Sheriffs Office
 1 Layman Way, Alfred, Maine 04002
 Ph: 207-459-2203 Email: ncthayer@yorkcountymaine.gov

Quote# 2021-10-17

Please see the quotation below for the Tek84 Intercept Whole Body Scanner.

Qty	Part Number	Description	MSRP	Ext. Price
1	SSD-017-1101	Tek84 Intercept Whole Body Security Scanning System High Strength Aluminum Unibody Frame 160Kv Monoblock Oil Cooled Generator 34" x 72" x 90" (79" top removed) foot print 4 Second Scan Time Variable Scanning Dosage from .25uSv to 2.0uSv Tethered Ethernet Connected Work Station with 27" Vertically Mounted Touch Screen Monitor PC with Windows Operating System and two(2) 1TB Hard Drives RAID 1,000,000 image storage capacity Transportable on Built In Heavy Duty Caster System With Corner Mounting Feet 16 Million Gray Scale Levels 110V/60hz 1Kva	\$205,000	\$139,000
1	INT- Shipping/Install and Calibration	Freight from San Diego, CA to Alfred ME	INC	INC
1	INT-TRAINING	2. Days Formal On Site Operator Training.	INC	INC
1	INT-WARRANTY-1	Two Year Parts and Labor Warranty on Entire System from time of installation Extended Warranty \$7,500.00 after year 2	INC TBD	INC. TBD
Special Luminary Site Pricing			Total \$139,000.00	
1	(Optional) PN 13282	FDA Approved Fully Integrated Thermal Scanner/Temperature Scanning	\$30,000	\$20,000

Quote Expiration: Jan 15, 2022

By execution of this Agreement by an authorized signature, the Customer agrees to purchase the Products specified subject to the terms and conditions set forth in the Agreement and subject to Tek84 Terms and Conditions available at www.Tek84.com

DAP: Destination- Alfred ME
 Terms: Net 30 Days
 Taxes: ADD as Necessary at or provide exemption certificate

Accepted By:
 Printed Name and Title: _____
 Authorized Signature: _____
 Date: _____

Tek84:
 Printed Name and Title: _____
 Authorized Signature: _____
 Date: _____

13495 Gregg Street
 Poway, CA 92064
 Phone: 858-676-5382
 www.Tek84.com

WISCONSIN DEPARTMENT OF JUSTICE

Applicant Hereby Applies to the DOJ for Financial Support for the Within-Described Project:

SUBGRANT #: 16578

DOJ USE ONLY

Receipt Date	Award Date	Subgrant Number(s)
		-- 16578

SHORT TITLE: Whole Body Thermal Security Scanner

1. Type of Funds for which you are applying.	() Coronavirus Emergency Supplemental Funds – County Criminal Justice Agencies		
2. Applicant	Name Of Applicant: Marquette County Sheriff's Department		County: Marquette
	Street Address: 67 Park Street		
	Address Line 2:		Address Line 3:
	City: Montello		State: WI Zip: 53949-9366
	Phone: 608-575-2308 Fax:		
	Email: rmiller@co.marquette.wi.us		
3. Recipient Agencies	Marquette County Sheriff's Department		
4. Signatory	Name: Chairman Robert Miller		Title: County Board Chair Agency: Marquette County
	Street Address: 77 West Park Street		
	Address Line 2:		Addr Line 3:
	City: Montello		State: WI Zip: 53949-9366
	Phone: 608-575-2308 Fax:		Email: rmiller@co.marquette.wi.us
	Agency: Marquette County Sheriff's Department		
5. Financial Officer	Name: Treasurer Jody A. Myers		Title: County Treasurer Agency: Marquette County Sheriff's Department
	Street Address: 67 Park Street		
	Address Line 2:		Addr Line 3:
	City: Montello		State: WI Zip: 53949-9366
	Phone: 608-297-3032 Fax:		Email: jmyers@co.marquette.wi.us
	Agency: Marquette County Sheriff's Department		
6. Project Director	Name: Sheriff Joseph R Konrath		Title: Sheriff Agency: Marquette County Sheriff's Department
	Street Address: 67 Park Street		
	Address Line 2:		Addr Line 3:
	City: Montello		State: WI Zip: 53949-9366
	Phone: 608-297-2115 Fax:		Email: jkonrath@co.marquette.wi.us
	Agency: Marquette County Sheriff's Department		
7. Brief Summary of Project (Do Not Exceed Space Provided)	Short Title (may not exceed 50 characters) Whole Body Thermal Security Scanner		
	The Marquette County Jail is approved by the Department of Corrections for the detention of adult offenders. There have been operational strains in 2020 and 2021 due to the COVID-19 pandemic. The issues have been assessed and addressed in a highly professional manner. To continue our effort for the safety and security of our correctional officers and inmates from the contagious disease, incorporating a Whole-Body Thermal Security Scanner will greatly improve the initial screening of newly incarcerated inmates for the detection of COVID-19. If the inmate body temperature is higher than normal the inmate can be placed in medical isolation pending the results of a COVID-19 test.		

8. SubGrant Budget

Categories	Sources	
	Federal	Category Total
Equipment	150,000.00	150,000.00
Supplies & Operating Expenses	0.00	0.00
Consultants/Contractual	0.00	0.00
Source Total	150,000.00	150,000.00

9. Project Start Date: 6/1/2021

Project End Date: 12/1/2021

10. Budget Details:

Master Budgets:

By Recipient Agency	Year 1	Total
Marquette County Sheriff's Department	150,000.00	150,000.00
Total:	150,000.00	150,000.00

Allocation/Recipient Agency: Marquette County Sheriff's Department

Category:	Year 1	Total
Equipment	150,000.00	150,000.00
Total:	150,000.00	150,000.00

11. Budget Details:

Master Budgets:

Line Item Details for Marquette County Sheriff's Department

YEAR 1

EQUIPMENT

Justification: The Coronavirus Emergency Supplemental Funds will be used to purchase the Whole Body Thermal Security Scanner. The cost of the unit is \$169,000.00 and the maximum funding of \$150,000.00 will no doubt assist with the purchase of the equipment. The equipment will be used for temperature taking of newly incarcerated inmates for the detection of COVID-19. This initial stage will protect the correctional officers and the inmates from the contagious virus spreading throughout the jail if the symptoms are detected early on. This will help determine if the inmates will have to go into medical isolation pending the COVID test. At the moment we only depend on the answers to the COVID-19 questionnaire.

COST

Item	Tek84 Intercept Whole Body and Thermal Security System		
Quantity:	1.00	Source: Federal	0.00
Unit Cost:	150,000.00	Source: Federal	150,000.00
	Equipment	Year 1 Total:	150,000.00

YEAR 1 TOTAL: 150,000.00

12. Sections:

A BUDGET NARRATIVE

The budget should display a clear link to the overall program or project and the proposed budgeted items. The budget narrative should explain how the costs are necessary for the completion of the proposed project.

RESPONSE:

The Coronavirus Emergency Supplemental Funds will make this project possible. The funding used towards the purchase of the Whole Body Thermal Security Scanner will change the process of the initial screening of COVID-19. Temperature taking at the initial stage of booking into the jail of newly incarcerated inmates will no doubt add to the safety and security of correctional staff and inmates. Without the funding we will not be able to purchase the equipment and COVID-19 can easily spread without notice. It is a strong preventive measure. The Whole Body Thermal Security Scanner is the most essential equipment for the early detection of the COVID-19 virus symptom.

BUDGET NARRATIVE - RELATED ATTACHMENTS:

File Name

File Description

B PROBLEM OR NEEDS DESCRIPTION

Describe the problem or issue your county criminal justice system is experiencing during the coronavirus response, explain how this grant funding will solve or diminish identified problems.

RESPONSE:

The Marquette County Sheriff's Office is the only 24/7 law enforcement agency in Marquette County. The Marquette County Jail is the only DOC approved correctional facility in Marquette County. The level of calls for service and subjects getting arrested for criminal violations has increased the risk of the COVID-19 virus spreading and affecting the correctional staff and inmates incarcerated in the jail. The jail population has increased substantially since a year ago when the COVID-19 pandemic first hit. The court opening more and more for in-person hearings has increased the risk of the COVID-19 virus spreading as defendants are pleading and getting sentence to serve time in the Marquette County Jail. For the first time in a year the Marquette County Circuit Court has five (5) jury trials scheduled in May. The criminal justice system is busier and having a Whole Body Security Thermal Scanner in the jail for the initial assessment of COVID-19 will no doubt help with the detection of COVID-19 and stop the possibility of the virus spreading throughout the jail affecting the correctional staff and inmates.

PROBLEM OR NEEDS DESCRIPTION - RELATED ATTACHMENTS:

File Name

File Description

C PROJECT NARRATIVE

Pending

RESPONSE:

The Whole Body Security Thermal Scanning System will be used for all incarcerations into the Marquette County Jail. The new policy for the use of the aforementioned equipment will be listed for the temperature taking of all newly arrested subjects entering the Marquette County Jail to detect COVID-19 symptoms. With the early detection of COVID-19 symptoms, arrestees, can be placed in medical isolation for a COVID-19 testing. This procedure will contribute to the safety, security and wellness of correctional staff and inmates. This will also prevent the possible spreading of the disease throughout the jail facility affecting other staff members and inmates. Early detection of COVID-19 symptoms will alert correctional officers and having a procedure in place will protect others from getting affected. This will add another precautionary measure in place for the protection, safety and security of correctional officers and inmates getting affected with the COVID-19 virus.

PROJECT NARRATIVE - RELATED ATTACHMENTS:

File Name

File Description

14. Approval Checklist:

A. Have you, the grant recipient, had any discrimination findings after a due process hearing on the basis of race, color, religion, national origin or sex within the last 5 years? (federal EEOP required response)

Yes

No

B. If yes, have the discrimination findings been reported to the Office of Civil Rights as required for all recipients of Federal funds? (see <http://www.ojp.usdoj.gov/ocr/>). If no, a copy should be forwarded to: Wisconsin Department of Justice, Attn: EEOP, 17 West Main Street, PO Box 7857, Madison, WI 53707-7857 (federal EEOP required response)

Yes

No

N/A

C. Have you utilized the DOJ Administrative Guide located on the DOJ website? (grants-admin-guide-2018.pdf)

Yes

No

D. Would you like someone from DOJ to contact you?

Yes

No

E. Are you a state or local government agency; AND have 50 or more employees; AND applying for \$25,000 or more? If yes, you are required to prepare and implement an Equal Employment Opportunity Plan (EEO) or Certification form (if applicable). A copy of your EEO federal approval letter must be submitted to DOJ. (More information may be found at <http://www.doj.state.wi.us/grants/grantee-civil-rights-information>) (federal EEO required response)

Yes

No

N/A

F. If this application is \$25,000 or more, did your business or organization (including parent organization, all branches, and all affiliates worldwide) receive in the previous fiscal year (1) 80% or more of your annual gross revenues in US federal contracts, subcontracts, loans, grants, subgrants, and/or cooperative agreements?; AND (2) \$25,000,000 or more in annual gross revenues from US federal contracts, subcontracts, loans, grants, subgrants, and/or cooperative agreements? (required by The Federal Funding Accountability and Transparency Act)

Yes

No

N/A

G. If you answered yes to the previous question, does the public have access to information about the compensation of the senior executives in your business or organization (including parent organization, all branches, and all affiliates worldwide) through periodic reports filed under section 13(a) or 15(d) of the Securities Exchange Act of 1934 (15 U.S.C. 78m(a), 78o(d)) or section 6104 of the Internal Revenue Code of 1986? If you answered no to the first part of this question; you must attach to this application the full names and compensation of the top 5 highly compensated individuals of your organization as required by The Federal Funding Accountability and Transparency Act.

Yes

No

N/A

Intercept Body Scanner

Recommendations for Pregnant Subjects and Employees

September 14, 2020

By Steven W. Smith, Ph.D.
President, Tek84 Inc.
Steve.Smith@Tek84.com

Summary

The FDA and other safety organizations have addressed the use of body scanners with pregnant subjects and workers. Body scanners operate within the radiation dose allowable for the General Public, less than 250 uSv per year. This is the lowest category defined for radiation protection. This radiation limit was enacted to protect the most vulnerable members of the population, including pregnant women, children and other groups that may have heightened sensitivity to radiation. Accordingly, for purposes of radiation protection, it is unwarranted to treat pregnant subjects or workers differently than other members of the population with regards to body scanner operation.

Body Scanner Regulation in the United States

There are three key documents for regulating x-ray body scanners in the United States:

1. ANSI/HPS N43.17-2009

Radiation Safety for Personnel Security Screening Systems Using X-ray or Gamma Radiation

This is the master regulatory document for body scanner operation in the United States and many other parts of the world. While this is a consensus standard with input from dozens of groups, most of this document was authored by employees of the FDA and represents the agency's official position. In addition, essentially every major radiation protection organization in the United States has endorsed the N43-17 standard. (39 pages)

2. NCRP Commentary Nr 16

Screening of Humans for Security Purposes Using Ionizing Radiation Scanning Systems

The National Council on Radiation Protection (NCRP) is the primary organization in the United States that sets radiation limits. In this commentary, NCRP specifically addresses radiation protection in the use of body scanners. (37 pages)

3. National Academies of Science Report to Congress

Airport Passenger Screening Using Backscatter X-ray Machines

The National Academies of Science (NAS) is one of the most respected scientific organizations in the world. Congress requested NAS to prepare this report in response to ongoing safety concerns over airport x-ray body scanners. The report was intended to be a comprehensive review of all existing studies and public commentaries. While focused on airport backscatter scanners, much of the material is relevant to the transmission scanners used by correctional institutions. (134 pages)

These organizations are closely aligned in their recommendations for body scanners and frequently cross-reference each other. That is, the provisions of the N43-17 standard should be interpreted as the joint recommendation of FDA, NCRP, and essentially every major radiation protection organization in the United States.

Radiation Dose Limit for the General Public

The NCRP has long set the annual radiation dose limit for the General Public at 1,000 uSv per year, excluding background radiation and medical examinations. Since a person may come in contact with several sources of radiation during the year, NCRP recommends that any one source or procedure should not produce more than 25% of this limit, or 250 uSv annually. This applies to all man-made sources of radiation, such as: smoke detectors, stray radiation from electronic equipment, nuclear power plants, and so on. For comparison, normal background radiation is also about 1,000 uSv per year at sea level, and twice that in Denver from the increased altitude.

Radiation Dose Limit for Body Scanners

NCRP and N43-17 require that body scanners operate within the dose levels already set for the General Public, the lowest category. That is, no person screened with body scanners will receive more than 250 uSv per year.

The “thin-person” setting on Intercept uses a radiation dose of 0.25 uSv per scan. That is, a person could be scanned up to 1,000 times per year on this setting. On the “heavy-person” setting the dose is 0.90 uSv, allowing up to 277 scans per year. Intercept keeps track of the accumulated dose each person receives to insure these requirements are met. The requirements can also be met by simply limiting the number of scans to the above values.

Screening Pregnant Women

It is widely recognized that pregnant women, children and various other individuals are more sensitive to radiation than other members of the public. Accordingly, the radiation limit for this subgroup is lower for both medical and occupational exposure. For instance, NCRP recommends that pregnant workers should receive less than 5,000 uSv during the pregnancy, about one-tenth that of a regular employee. These occupational exposure levels are primarily enforced by OSHA.

However, the radiation limit for the General Public, 250 uSv per year, is already more than 20 times lower than this occupational limit for pregnant workers. Further, NCRP and N43-17 make clear that the General Public category inherently includes pregnant women, children, and other special groups. That is, the dose recommendation for the General Public was intentionally made low enough to protect this subgroup of radiation sensitive persons.

Because body scanners operate within the General Public category, there is no justification in radiation safety for treating pregnant women differently than others, either as subjects or employees.

Pregnant Employees

NCRP and N43-17 provide that scanner operators and bystanders be treated as members of the General Public, with a maximum allowable dose of 250 uSv per year. They are not classified as radiation workers, and are not allowed the higher occupational dose level of OSHA regulations.

At four feet from the scanner, the closest an employee would normally stand, Intercept produces about 0.01 uSv per scan on the highest setting. That is, an employee could stand in this position for up to 25,000 scans conducted in one year.

There is little chance that any employee will exceed the 250 uSv annual limit in normal operation. Accordingly, Institutions generally do not need to enact procedures for radiation protection of employees, other than routine good practices. During training, operators are instructed to keep all personnel at least four feet away from the scanner during normal operation, but may occasionally stand closer if needed for an operational reason. Excluding pregnant employees from these duties or procedures is not warranted for radiation protection. This is also the stated position of the NCRP and N43-17.

Recommendations for Institutional Procedures

Every Institution should strive to align its operational procedures with the N43-17 standard. This gives the Institution the backing of essentially every radiation protection organization in the United States. The primary requirement is that no person exceeds a radiation exposure of 250 uSv per year, including pregnant women, both as subjects and operators.

Of course, there are valid reasons why an Institution may refrain from scanning pregnant subjects, other than radiation safety. For instance, the fetus will appear in the scanned image during later portions of the pregnancy, presenting a variety of issues. If an Institution elects to avoid scanning pregnant women for such reasons, it should be cautious not to imply that it is done for the purpose of radiation safety.

Commissioners
Randy T. Church, Chairman Michael
W. LaBrose, Vice Chairman

Jeff Branch
Donnie Potter
Robbie Wilkie

Tony Helton, Interim County Manager



County of Caldwell
PO Box 2200
Lenoir, NC 28645
Phone (828) 757-1300
Fax (828) 757-1205

www.caldwelldcountync.org

AMERICAN RESCUE PLAN ACT REIMBURSEMENT FORM

Date: 8/23/2021

Project Title: Protective Measures Caldwell County Detention Facility - Body Scanner

(i.e. PPE, Disinfectant, Protective Measures, Payroll, Equipment etc.)

ARPA-11

Project Description/Justification:

The project for this grant is for the purchase and implementation of a system to completely search individuals that enter our Correctional Facility for illegal contraband. This system shall complete a full body scan to detect cell phones, weapons, and other items that can be hidden in body cavities or elsewhere on inmates or visitors.

Systems such as this are currently in place in other facilities throughout NC but our facility does not own or operate one. Our current method for searching relies on the antiquated hands-on physical search by the correctional staff and utilizing non-reliable squat and cough methods for items hidden inside a body cavity.

Even during the pandemic year of 2020, the Caldwell County Jail processed 4750 inmates. With an estimated time of a half hour per inmate this totals 2,875 hours of manpower spent. The systems that are now available require someone to stand still for 4 seconds and the process is over saving taxpayer money.

There will be a minimum of eighteen agencies that will benefit from the purchase and use of this type of equipment in our facility. They range from the Federal Government since we house their inmates to our own local jurisdictions and probation and parole.

By receiving the project approval the correction officers can remain at a social distance while ensuring that illegal contraband will not enter our facility.

Project Cost: \$ 169,000

(Attach Quote or Receipt)

Entity Requesting: Caldwell County Sheriff's Office

(County Government - Department)

[Signature]
Authorized Official - Signature/Title

OC ✓
8-23-21
Approved

Denied

[Signature]
Authorized Official (Consultant)

ARPA-11

Authorized Official (Caldwell County)

Mitigating the impact of COVID-19, including taking actions to control its spread and support hospitals and health care workers caring for the sick, continues to require a major public health response from State, local and Tribal governments. New or heightened public health needs include COVID-19 testing, major expansions in contact tracing, support for individuals in isolation or quarantine, enforcement of public health orders, new public communication effort, public health surveillance (e.g., monitoring case trends and genomic sequencing for variants), enhancement to health care capacity through alternative care facilities, and enhancement of public health data systems to meet new demands or scaling needs. State, local, and Tribal governments have also supported major efforts to prevent COVID-19 spread through safety measures at key settings like nursing homes, schools, congregate living settings, dense worksites, incarceration settings, and in other public facilities. This has included implementing infection prevention measures or making ventilation improvements in congregate settings, health care settings, or other key locations.

Other response and adaptation costs include capital investments in public facilities to meet pandemic operational needs, such as physical plant improvements to public hospitals and health clinics or adaptations to public buildings to implement COVID-19 mitigation tactics. In recent months, State, local, and Tribal governments across the country have mobilized to support the national vaccination campaign, resulting in over 250 million doses administered to date.

The need for public health measures to respond to COVID-19 will continue in the months and potentially years to come. This includes the continuation of the vaccination campaign for the general public and, if vaccinations are approved for children in the future, eventually for

² Centers for Disease Control and Prevention, COVID Data Tracker: COVID-19 Vaccinations in the United States, <https://covid.cdc.gov/covid-data-tracker/#vaccinations> (last visited May 8, 2021).

Sales Quotation

Thermo Scientific Portable Analytical Instruments Inc.

2 Radcliff Rd
Tewksbury, Massachusetts 01876
United States

Quote Number	Created Date	Exp. Delivery Terms	Page
00254406	10/18/2021	ARO	1 / 8
Contact:	Phone	Payment Term	Valid To
Michael Nagle		Net 30	12/31/2021
Inco Terms		Shipping Method	
FOB Origin - Tewksbury		Fed Ex 2nd Day	

Submitted To:

Jeremy Forbes
York County Sheriff's Office
1 Layman Way
Alfred, Maine 04002
United States

Phone: (207) 468-6084
Email: jdforbes@yorkcountymaine.gov

THANK YOU FOR YOUR INTEREST IN THERMO SCIENTIFIC INSTRUMENTATION

To Place an Order:	
Contact:	Mike Nagle
Phone:	(617) 716-9831
Fax:	
Email:	michael.nagle@thermofisher.com
Additional instructions, terms & conditions on last page	

GSA Contract No. GS-07F-6099R

Contract period: March 26, 2010 - September 28, 2025
SIN 334519
SIN 339999E

When placing a purchase order against this quote, please use the Mandatory PO language for state/local orders using the Cooperative Purchasing Program as follows:

"This order is placed under GSA contract number GS-07F-6099R under the authority of the GSA Cooperative Purchasing Program. In the event of a conflict between the terms of this order and those of the GSA Schedule, GSA's terms shall govern."

Pos.	Product Code	Product Name	Sales Price	Quantity	Total Price
1.00	800-01045-01	TruNarc, Unlimited, Warranty - 5 Yrs, Train-12	USD 30,265.99	1.00	USD 30,265.99
	GSA Item	TruNarc Unlimited Model with 5 years of warranty. Includes factory repair, loaner units when available and 24/7 technical support. Companion PC TruNarc admin software, unlimited access to TruNarc eLearning course and free basic software updates to core narcotics library are provided for the life of the instrument. Includes TruNarc on-site instructor led training for up to 12 students within the Continental United States (CONUS) - expires 9 months after date of purchase.			
2.00	810-01461-01	TruNarc Solution Kit (Type H) - 20, English	USD 0.00	2.00	USD 0.00
	Open Market Item	TruNarc Solution Kit (Type H) for identification of Heroin and other special narcotics. Kit includes 20 Test Sticks and 20 Solution Vials with Ethanol. Note that because of the Ethanol, this product ships as a Hazardous Goods shipment. The shelf life for Type H-sticks is approximately one year from shipment.			
3.00	820-01052-01	TruNarc, Unlimited, Warranty Renewal - 2 Yrs	USD 0.00	1.00	USD 0.00

When applicable, commodities, technology, or software to be provided in furtherance of this order shall be exported from the United States in accordance with applicable U.S export laws or regulations. Diversion contrary to US law prohibited. Unless otherwise agreed to in writing, Thermo Scientific Portable Analytical Instruments Inc. terms and conditions shall apply and take precedence.

GSA Item

Warranty for 2 years for a TruNarc Unlimited instrument (for instruments up to 5th year). Includes factory repair and loaner units when available. Companion PC TruNarc admin software, unlimited access to TruNarc eLearning course and free basic software updates to core narcotics library are provided for the life of the instrument.

Total: USD 30,265.99

Important Note: Please issue POs to Thermo Scientific Portable Analytical Instruments Inc

Federal Tax ID No.: 01-0650031

CAGE CODE: 392A9

DUNS #: 11-289-3131

Bank of America ABA# for Wire Payments: 026 009 593

Bank of America ABA# for ACH Payments: 111 000 012

Beneficiary Account Number: 4426843850

When applicable, commodities, technology, or software to be provided in furtherance of this order shall be exported from the United States in accordance with applicable U.S export laws or regulations. Diversion contrary to US law prohibited. Unless otherwise agreed to in writing, Thermo Scientific Portable Analytical Instruments Inc. terms and conditions shall apply and take precedence.

Acceptance of Purchase

By signing below, you (i) warrant that you are an authorized representative of your company, (ii) agree that the Thermo Scientific Portable Analytical I attached hereto (the "Terms and Conditions") shall supersede any preprinted terms and conditions, in their entirety, contained in any purchase order Conditions shall exclusively govern the transaction(s) contemplated hereby

Signature of authorized company representative	Date	Phone#
Print Name	Title	Email
Model #	Amount + S&H	Purchase Order

E-mail to: pai.sales.ops@thermofisher.com

Fax to: 1-877-680-2568

Order Processing Address:

michael.nagle@thermofisher.com

Thermo Scientific Portable Analytical Instruments Inc

2 Radcliff Road

Tewksbury, MA 01876

Remit check Payment To:

Thermo Scientific Portable Analytical Instruments Inc

PO Box 415918

Boston, MA 02241-415918

Payment Details

Method of Payment

- Net 30 (Attach Credit Application & Credit References)
- Credit Card
- Check
- Wire Transfer

Sales Tax Application

- Yes Apply Sales Tax
- No

- If no, you must provide a copy of your tax exemption certificate along with your purchase order.

Please contact your customer service representative with your credit card information. (Do not send any credit card info via email or fax.)

Address Verification

Please make corrections if necessary below:

Bill to:

1 Layman Way
Alfred, Maine 04002
United States

Ship to:

1 Layman Way
Alfred, Maine 04002
United States

When applicable, commodities, technology, or software to be provided in furtherance of this order shall be exported from the United States in accordance with applicable U.S export laws or regulations. Diversion contrary to US law prohibited. Unless otherwise agreed to in writing, Thermo Scientific Portable Analytical Instruments Inc. terms and conditions shall apply and take precedence.

Additional Options / Accessories

Please use the space below to note any additional options and/or accessories you wish to add from the attached sheets that are not included in the above quotation.

When applicable, commodities, technology, or software to be provided in furtherance of this order shall be exported from the United States in accordance with applicable U.S export laws or regulations. Diversion contrary to US law prohibited. Unless otherwise agreed to in writing, Thermo Scientific Portable Analytical Instruments Inc. terms and conditions shall apply and take precedence.

THERMO SCIENTIFIC PORTABLE ANALYTICAL INSTRUMENTS INC – TERMS AND CONDITIONS OF SALE

Last revised November 2019

UNLESS OTHERWISE EXPRESSLY AGREED IN WRITING, ALL SALES ARE SUBJECT TO THE FOLLOWING TERMS AND CONDITIONS:

1. **GENERAL.** Thermo Scientific Portable Analytical Instruments Inc ("Seller") hereby offers for sale to the buyer named on the face hereof ("Buyer") the products listed on the face hereof (the "Products") on the express condition that Buyer agrees to accept and be bound by the terms and conditions set forth herein. Any provisions contained in any document issued by Buyer are expressly rejected and if the terms and conditions in this agreement (the "Agreement") differ from the terms of Buyer's offer, this document shall be construed as a counter offer and shall not be effective as an acceptance of Buyer's document. Buyer's receipt of Products or Seller's commencement of the services provided hereunder will constitute Buyer's acceptance of this Agreement. This is the complete and exclusive statement of the contract between Seller and Buyer with respect to Buyer's purchase of the Products. No waiver, consent, modification, amendment or change of the terms contained herein shall be binding unless in writing and signed by Seller and Buyer. Seller's failure to object to terms contained in any subsequent communication from Buyer will not be a waiver or modification of the terms set forth herein. All orders are subject to acceptance in writing by an authorized representative of Seller.

2. **PRICE.** All prices published by Seller or quoted by Seller's representatives may be changed at any time without notice. All prices quoted by Seller or Seller's representatives are valid for thirty (30) days, unless otherwise stated in writing. All prices for the Products will be as specified by Seller or, if no price has been specified or quoted, will be Seller's price in effect at the time of shipment. All prices are subject to adjustment on account of specifications, quantities, raw materials, cost of production, shipment arrangements or other terms or conditions, which are not part of Seller's original price quotation.

3. **TAXES AND OTHER CHARGES.** Prices for the Products exclude all sales, value added and other taxes and duties imposed with respect to the sale, delivery, or use of any Products covered hereby, all of which taxes and duties must be paid by Buyer. If Buyer claims any exemption, Buyer must provide a valid, signed certificate or letter of exemption for each respective jurisdiction. Buyer shall be solely responsible for obtaining any and all necessary licenses, registrations, certificates, permits, approvals or other authorizations required by federal, state or local statute, law or regulation pertaining to the use or possession of the products contemplated herein that include radioactive isotopes, or x-ray tubes if any.

Buyer shall pay Seller such surcharges, or other fees, in respect of the sale of Products hereunder as Seller deems necessary and appropriate (in Seller's sole, good-faith, reasonable discretion) to account for changes in the cost to product, develop, market, or sell the Products to Buyer hereunder (whether as the result of the imposition of tariffs or otherwise). All such surcharges must be paid by Buyer in accordance with the payment terms set forth herein. Buyer agrees that such surcharges, or other fees, or any termination thereof, shall take effect immediately upon written notice thereof by Seller to Buyer. In the event that Seller's quote and/or order acknowledgement set forth surcharges, those documents shall be considered adequate written notice to Buyer that said surcharges are Buyer's responsibility. Any such surcharges shall not constitute an increase in the Price(s) of any Products or Services sold under this Agreement

4. **TERMS OF PAYMENT.** Seller may invoice Buyer upon shipment for the price and all other charges payable by Buyer in accordance with the terms on the face hereof. If no payment terms are stated on the face hereof, payment shall be net thirty (30) days from the date of invoice. If Buyer fails to pay any amounts when due, Buyer shall pay Seller interest thereon at a periodic rate of one and one-half percent (1.5%) per month (or, if lower, the highest rate permitted by law), together with all costs and expenses (including without limitation reasonable attorneys' fees and disbursements and court costs) incurred by Seller in collecting such overdue amounts or otherwise enforcing Seller's rights hereunder. Seller reserves the right to require from Buyer full or partial payment in advance, or other security that is satisfactory to Seller, at any time that Seller believes in good faith that Buyer's financial condition does not justify the terms of payment specified. All payments shall be made in U.S. Dollars.

5. **DELIVERY CANCELLATION OR CHANGES BY BUYER.** The Products will be shipped to the destination specified by Buyer, F.O.B. shipping point. Seller will have the right, at its election, to make partial shipments of the Products and to invoice each shipment separately. Seller reserves the right to stop delivery of Products in transit and to withhold shipments in whole or in part if Buyer fails to make any payment to Seller when due or otherwise fails to perform its obligations hereunder. All shipping dates are approximate only, and Seller will not be liable for any loss or damage resulting from any delay in delivery or failure to deliver which is due to any cause beyond Seller's reasonable control. In the event of a delay due to any cause beyond Seller's reasonable control, Seller reserves the right to terminate the order or to reschedule the shipment within a reasonable period of time, and Buyer will not be entitled to refuse delivery or otherwise be relieved of any obligations as the result of such delay. Products as to which delivery is delayed due to any cause within Buyer's control may be placed in storage by Seller at Buyer's risk and expense and for Buyer's account. Orders in process may be canceled only with Seller's written consent and upon payment of Seller's cancellation charges. Orders in process may not be changed except with Seller's written consent and upon agreement by the parties as an appropriate adjustment in the purchase price therefor. Credit will not be allowed for Products returned without prior written consent of seller.

6. **RETURN OF PRODUCTS/RESTOCKING CHARGE.** Buyer must obtain permission from Seller prior to returning Products. The request must be received within ten (10) days of receipt of the Products. Older items, service parts, and discontinued items cannot be returned for credit. In order to obtain a RMA number, Buyer must contact Seller's customer support. Seller, in its discretion, may impose a twenty (20%) percent restocking charge of the price paid for any item authorized for return for credit

7. **TITLE AND RISK OF LOSS.** Notwithstanding the trade terms indicated above and subject to Seller's right to stop delivery of Products in transit, title to and risk of loss of the Products will pass to Buyer upon delivery of possession of the Products by Seller to the carrier irrespective of which Party's carrier is used for the transport or the manner of payment ascribed to the transport; provided, however, that title to any software incorporated within or forming a part of the Products shall at all times remain with Seller or the licensor(s) thereof, as the case may be.

8. **WARRANTY.** Seller warrants that the Products will operate or perform substantially in conformance with Seller's published specifications and be free from defects in material and workmanship, when subjected to normal, proper and intended usage by properly trained personnel, for the period of time set forth in the product documentation, published specifications or package inserts. If a period of time is not specified in Seller's product documentation, published specifications or package inserts, the warranty period shall be one (1) year from the date of shipment to Buyer for equipment and ninety (90) days for all other products (the "Warranty Period"). During the Warranty Period, Seller agrees, in its sole discretion, to repair or replace, Products and/or provide additional parts or services as reasonably necessary to cause the same to perform in substantial conformance with said published specifications; provided that Buyer shall (a) promptly notify Seller in writing upon the discovery of any defect, which notice shall include the product model and serial number (if applicable) and details of the warranty claim; and (b) after Seller's review, Seller will provide Buyer with service data and /or a Return Material Authorization ("RMA"), which may include biohazard decontamination procedures and other product-specific handling instructions, then, if applicable, Buyer may return the defective Products to Seller with all costs prepaid by Buyer. Replacement parts may be new or refurbished, at the election of Seller. All replaced parts shall become

the property of Seller. Shipment to Buyer of repaired or replacement Products shall be made in accordance with the Delivery provisions of the Seller's Terms and Conditions of Sale. Consumables are expressly excluded from this warranty. If Seller elects to repair defective device instruments, Seller may, in its sole discretion, provide a replacement loaner instrument to Buyer as necessary for use while the instruments are being repaired. Notwithstanding the foregoing, Products supplied by Seller that are obtained by Seller from an original manufacturer or third party supplier are not warranted by Seller, but Seller agrees to assign to Buyer any warranty rights in such Product that Seller may have from the original manufacturer or third party supplier, to the extent such assignment is allowed by such original manufacturer or third party supplier. In no event shall Seller have any obligation to make repairs, replacements or corrections required, in whole or in part, as the result of (i) normal wear and tear, (ii) accident, disaster or event of force majeure, (iii) misuse, fault or negligence of or by Buyer, (iv) use of the Products in a manner for which they were not designed, (v) causes external to the Products such as, but not limited to, power failure or electrical power surges, (vi) improper storage and handling of the Products or (vii) use of the Products in combination with equipment or software not supplied by Seller. If Seller determines that Products for which Buyer has requested warranty services are not covered by the warranty hereunder, Buyer shall pay or reimburse Seller for all costs of investigating and responding to such request at Seller's then prevailing time and materials rates. If Seller provides repair services or replacement parts that are not covered by this Warranty shall pay Seller therefor at Seller's then prevailing time and materials rates.

ANY INSTALLATION, MAINTENANCE, REPAIR, SERVICE, RELOCATION OR ALTERATION TO OR OF, OR OTHER TAMPERING WITH, THE PRODUCTS PERFORMED BY ANY PERSON OR ENTITY OTHER THAN SELLER WITHOUT SELLER'S PRIOR WRITTEN APPROVAL, OR ANY USE OF REPLACEMENT PARTS NOT SUPPLIED BY SELLER, SHALL IMMEDIATELY VOID AND CANCEL ALL WARRANTIES WITH RESPECT TO THE AFFECTED PRODUCTS. THE OBLIGATIONS CREATED BY THIS WARRANTY STATEMENT TO REPAIR OR REPLACE A DEFECTIVE PRODUCT SHALL BE THE SOLE REMEDY OF BUYER IN THE EVENT OF A DEFECTIVE PRODUCT. EXCEPT AS EXPRESSLY PROVIDED IN THIS WARRANTY STATEMENT, SELLER DISCLAIMS ALL OTHER WARRANTIES, WHETHER EXPRESS OR IMPLIED, ORAL OR WRITTEN, WITH RESPECT TO THE PRODUCTS, INCLUDING WITHOUT LIMITATION ALL IMPLIED WARRANTIES OF MERCHANTABILITY OR FITNESS FOR ANY PARTICULAR PURPOSE. SELLER DOES NOT WARRANT THAT THE PRODUCTS ARE ERROR-FREE OR WILL ACCOMPLISH ANY PARTICULAR RESULT.

9. INDEMNIFICATION

9.1. By Seller. Seller agrees to indemnify, defend and save Buyer, its officer, directors, and employees from and against any and all damages, liabilities, actions, causes of action, suits, claims, demands, losses, costs and expenses (including without limitation reasonable attorney's fees) ("Indemnified Items") for (i) injury to or death of persons or damage to property to the extent caused by the negligence or willful misconduct of Seller, its employees, agents or representatives or contractors in connection with the performance of services at Buyer's premises under this Agreement and (ii) claims that a Product infringes any valid United States patent, copyright or trade secret; provided, however, Seller shall have no liability under this Section to the extent any such Indemnified Items are caused by either (i) the negligence or willful misconduct of Buyer, its employees, agents or representatives or contractors, (ii) by any third party, (iii) use of a Product in combination with equipment or software not supplied by Seller where the Product would not itself be infringing, (iv) compliance with Buyer's designs, specifications or instructions, (v) use of the Product in an application or environment for which it was not designed or (vi) modifications of the Product by anyone other than Seller without Seller's prior written approval. Buyer shall provide Seller prompt written notice of any third party claim covered by Seller's indemnification obligations hereunder. Seller shall have the right to assume exclusive control of the defense of such claim or, at the option of the Seller, to settle the same. Buyer agrees to cooperate reasonably with Seller in connection with the performance by Seller of its obligations in this Section.

Notwithstanding the above, Seller's infringement related indemnification obligations shall be extinguished and relieved if Seller, at its discretion and at its own expense (a) procures for Buyer the right, at no additional expense to Buyer, to continue using the Product; (b) replaces or modifies the Product so that it becomes non-infringing, provided the modification or replacement does not adversely affect the specifications of the Product; or (c) in the event(a) and (b) are not practical, refund to Buyer the amortized amounts paid by Buyer with respect thereto, based on a five (5) year amortization schedule. THE FOREGOING INDEMNIFICATION PROVISION STATES SELLER'S ENTIRE LIABILITY TO BUYER FOR THE CLAIMS DESCRIBED HEREIN.

9.2. By Buyer. Buyer shall indemnify, defend with competent and experienced counsel and hold harmless Seller, its parent, subsidiaries, affiliates and divisions, and their respective officers, directors, shareholders and employees, from and against any and all damages, liabilities, actions, causes of action, suits, claims, demands, losses, costs and expenses (including without limitation reasonable attorneys' fees and disbursements and court costs) to the extent arising from or in connection with (i) the negligence or willful misconduct of Buyer, its agents, employees, representatives or contractors; (ii) use of a Product in combination with equipment or software not supplied by Seller where the Product itself would not be infringing; (iii) Seller's compliance with designs, specifications or instructions supplied to Seller by Buyer; (iv) use of a Product in an application or environment for which it was not designed; or (v) modifications of a Product by anyone other than Seller without Seller's prior written approval

10. SOFTWARE. With respect to any software products incorporated in or forming a part of the Products hereunder, Seller and Buyer intend and agree that such software products are being licensed and not sold, and that the words "purchase", "sell" or similar or derivative words are understood and agreed to mean "license", and that the word "Buyer" or similar or derivative words are understood and agreed to mean "licensee". Notwithstanding anything to the contrary contained herein, Seller or its licensor, as the case may be, retains all rights and interest in software products provided hereunder. Seller hereby grants to Buyer a royalty-free, non-exclusive, nontransferable license, without power to sublicense, to use software provided hereunder solely for Buyer's own internal business purposes on the hardware products provided hereunder and to use the related documentation solely for Buyer's own internal business purposes. This license terminates when Buyer's lawful possession of the hardware products provided hereunder ceases, unless earlier terminated as provided herein. Buyer agrees to hold in confidence and not to sell, transfer, license, loan or otherwise make available in any form to third parties the software products and related documentation provided hereunder. Buyer may not disassemble, decompile or reverse engineer, copy, modify, enhance or otherwise change or supplement the software products provided hereunder without Seller's prior written consent. Seller will be entitled to terminate this license if Buyer fails to comply with any term or condition herein. Buyer agrees, upon termination of this license, immediately to return to Seller all software products and related documentation provided hereunder and all copies and portions thereof

11. LIMITATION OF LIABILITY. NOTWITHSTANDING ANYTHING TO THE CONTRARY CONTAINED HEREIN, THE LIABILITY OF SELLER UNDER THESE TERMS AND CONDITIONS (WHETHER BY REASON OF BREACH OF CONTRACT, TORT, INDEMNIFICATION, OR OTHERWISE, BUT EXCLUDING LIABILITY OF SELLER FOR BREACH OF WARRANTY (THE SOLE REMEDY FOR WHICH SHALL BE AS PROVIDED UNDER SECTION 8 ABOVE)) SHALL NOT EXCEED AN AMOUNT EQUAL TO THE LESSER OF (A) THE TOTAL PURCHASE PRICE THEREFORE PAID BY BUYER TO SELLER WITH RESPECT TO THE PRODUCT(S) GIVING RISE TO SUCH LIABILITY OR (B)

ONE MILLION DOLLARS (\$1,000,000). NOTWITHSTANDING ANYTHING TO THE CONTRARY CONTAINED HEREIN, IN NO EVENT SHALL SELLER BE LIABLE FOR ANY INDIRECT, SPECIAL, CONSEQUENTIAL OR INCIDENTAL DAMAGES (INCLUDING WITHOUT LIMITATION DAMAGES FOR LOSS OF USE OF FACILITIES OR EQUIPMENT, LOSS OF REVENUE, LOSS OF DATA, LOSS OF PROFITS OR LOSS OF GOODWILL), REGARDLESS OF WHETHER SELLER (a) HAS BEEN INFORMED OF THE POSSIBILITY OF SUCH DAMAGES OR (b) IS NEGLIGENT

12. **EXPORT RESTRICTIONS.** Buyer acknowledges that each Product and any related software and technology, including technical information supplied by Seller or contained in documents (collectively "Items"), is subject to export controls of the U.S. government. The export controls may include, but are not limited to, those of the Export Administration Regulations of the U.S. Department of Commerce (the "EAR"), which may restrict or require licenses for the export of Items from the United States and their re-export from other countries. Buyer shall comply with the EAR and all other applicable laws, regulations, laws, treaties, and agreements relating to the export, re-export, and import of any Item. Buyer shall not, without first obtaining the required license to do so from the appropriate U.S. government agency; (i) export or re-export any Item, or (ii) export, re-export, distribute or supply any Item to any restricted or embargoed country or to a person or entity whose privilege to participate in exports has been denied or restricted by the U.S. government. Buyer shall, if requested by Seller, provide information on the end user and end use of any Item exported by the Buyer or to be exported by the Buyer. Buyer shall cooperate fully with Seller in any official or unofficial audit or inspection related to applicable export or import control laws or regulations, and shall indemnify and hold Seller harmless from, or in connection with, any violation of this Section by Buyer or its employees, consultants, or agents

13. **HAZARDOUS MATERIALS.** Some Products may require special packaging, labeling, marking and handling. Carriers may add additional freight charges for the handling or transporting of these materials. The consolidating of such material with other Products may be prohibited. Additional freight charges will be billed per Seller's shipping terms. Be sure to advise Seller of shipping instructions for these hazardous materials to reduce your freight costs

14. **MISCELLANEOUS.** (a) Buyer may not delegate any duties nor assign any rights or claims hereunder without Seller's prior written consent, and any such attempted delegation or assignment shall be void. (b) The rights and obligations of the parties hereunder shall be governed by and construed in accordance with the laws of the State of Seller's manufacturing location, without reference to its choice of law provisions. Each party hereby irrevocably consents to the exclusive jurisdiction of the state and federal courts located in the county and state of Seller's manufacturing location, in any action arising out of or relating to this Agreement. (c) Both parties waive any right they may have under applicable law or otherwise to a right to a trial by jury. Any action arising under this Agreement must be brought within one (1) year from the date that the cause of action arose. (d) The application to this Agreement of the U.N. Convention on Contracts for the International Sale of Goods is hereby expressly excluded. (e) In the event that any one or more provisions contained herein shall be held by a court of competent jurisdiction to be invalid, illegal or unenforceable in any respect, the validity, legality and enforceability of the remaining provisions contained herein shall remain in full force and effect, unless the revision materially changes the bargain. (f) Seller's failure to enforce, or Seller's waiver of a breach of, any provision contained herein shall not constitute a waiver of any other breach or of such provision. (g) Unless otherwise expressly stated on the Product or in the documentation accompanying the Product, the Product is intended for non-clinical, non-diagnostic, non-therapeutic use only and is not to be used for any other purpose, including without limitation, unauthorized commercial uses, in vitro diagnostic uses, ex vivo or in vivo therapeutic uses, or any type of consumption by or application to humans or animals. (h) Buyer agrees that all pricing, discounts and technical information that Seller provides to Buyer are the confidential and proprietary information of Seller. Buyer agrees to (1) keep such information confidential and not disclose such information to any third party, and (2) use such information solely for Buyer's internal purposes and in connection with the Products supplied hereunder. Nothing herein shall restrict the use of information available to the general public. (i) Any notice or communication required or permitted hereunder shall be in writing and shall be deemed received when personally delivered or three (3) business days after being sent by certified mail, postage prepaid, to a party at the address specified herein or at such other address as either party may from time to time designate to the other (j) Seller hereby rejects and disclaims any rights of Buyer contained, or obligations imposed upon Seller, in any document provided, referenced or otherwise submitted by Buyer, in each case, that Seller has not expressly included in these [terms and conditions] or a writing manually executed by Seller (including, without limitation, any rights of Buyer in respect of designs, specifications, source code or intellectual property, owned, created, developed or licensed, by Seller; any rights to items or services not specifically identified in Seller's quotation; any audit rights or financial offset rights of Buyer; any penalties or liquidated damages imposed upon Seller; any obligation by Seller to comply with Health Insurance Portability and Accountability Act of 1996 (as amended), Current Good Manufacturing Practice regulations (as amended), the requirements, as amended, of the Customs-Trade Partnership Against Terrorism or any code of conduct, quality program, information security program, background or drug screening program or other guidelines, programs or policies, in each case, promulgated or required by Buyer; any obligation that Seller comply with any law that, under law, would not otherwise apply to Seller in respect of the transaction(s) contemplated hereby; any right of Buyer to withhold all, or any portion, of the purchase price of any products or services provided hereunder for any period of time; any right of Buyer, itself or through any third party, to remediate any defects in, replace or re-perform, any products or services provided hereunder at Seller's cost or expense; any obligation of Seller to waive, or require its insurers to waive, any rights of subrogation; any obligation of Seller that would impair, restrict or prohibit Seller's ability to freely conduct any business with any person or in any geography or market; any early-payment, or other, discount; any obligation of Seller to maintain a supply of spares, or otherwise make any services available, for any particular period of time; any representation, warranty or other obligation of Seller to provide pricing comparable to, or more favorable than, the pricing that Seller provides to others; any restriction of, or prohibition on, Seller's ability to modify, change or discontinue any of its products, processes or services; or any waiver by Seller of any right to enforce any of the terms hereof).

15. **SOFTWARE-AS-A-SERVICE TRANSACTIONS.** IF YOU ARE PURCHASING ANY PRODUCTS PROVIDED BY SELLER HEREUNDER AND DESCRIBED IN THE RELEVANT QUOTATION OR PURCHASE ORDER AS A SUBSCRIPTION TO ANY THERMO FISHER SOFTWARE-AS-A-SERVICE OFFERING (ANY SUCH PRODUCT, HEREINAFTER, A "SUBSCRIPTION"), THEN IN RESPECT OF SUCH SUBSCRIPTION(S) ONLY

(a) The following terms and conditions of this Agreement shall not apply: Sections 6-7, 9.1, and 13.

(b) The following terms and conditions of this Agreement shall be modified as set forth below:

(i) Section 5 shall be replaced in its entirety with the following:

5. **CANCELLATION OR CHANGES BY BUYER.** Seller reserves the right to suspend or terminate the Buyer's Subscription(s), in whole or in part, if Buyer fails to make any payment to Seller when due, otherwise fails to perform its obligations hereunder, or fails to comply with the Seller's Terms of Use agreement agreed to by Buyer and governing Buyer's use of the Subscription(s), as in effect from time to time (the "Terms of Use"). Seller will not be liable for any loss or damage resulting from any delay in activation of the Subscription(s) or failure to activate the Subscription(s) which is due to any cause beyond Seller's reasonable control. In the event of a delay due to any cause beyond Seller's reasonable control, Seller reserves the right to terminate the order or to reschedule the activation of the Subscription(s) within a reasonable period of time, and Buyer will not be entitled to refuse payment or otherwise be relieved of any obligations as the result of such delay. Orders in process may be canceled only with Seller's written consent and upon

payment of Seller's cancellation charges. Orders in process may not be changed except with Seller's written consent and upon agreement by the parties as an appropriate adjustment in the purchase price therefor.

(ii) Section 8 shall be replaced in its entirety with the following:

8. **WARRANTY.** BUYER AGREES AND ACKNOWLEDGES THAT THE SUBSCRIPTIONS ARE SOLD "AS-IS", WITH NO WARRANTIES EXPRESSED OR IMPLIED. SELLER DISCLAIMS ALL EXPRESS OR IMPLIED WARRANTIES, ORAL OR WRITTEN, WITH RESPECT TO THE SUBSCRIPTIONS, INCLUDING WITHOUT LIMITATION ALL IMPLIED WARRANTIES OF MERCHANTABILITY OR FITNESS FOR ANY PARTICULAR PURPOSE.

(iii) Section 10 shall be replaced in its entirety with the following:

10. **SOFTWARE.** This Agreement shall not be construed to grant to Buyer any patent license, know-how license or any other rights except as specifically provided herein. Buyer agrees and acknowledges that, by virtue of its purchase of the Subscriptions hereunder, it does not acquire any intellectual property rights (whether by license, assignment, or otherwise) of Seller, including without limitation any rights to the Subscriptions or related software or hardware systems (except for the limited right to use the Subscription subject to the terms and conditions set forth herein). Buyer shall not reverse engineer or copy the design, algorithms, or code, or any components thereof, of any information related to the Subscriptions for any purpose.

(iv) In Section 11, the language "ONE MILLION DOLLARS (\$1,000,000)" shall be replaced with "TEN THOUSAND DOLLARS (\$10,000)".

(c) The following additional terms and conditions shall apply

TERMS OF USE. Buyer hereby acknowledges and agrees that it shall comply with all terms and conditions of the Terms of Use, and that Buyer's use of the Subscription in violation of any such terms and/or conditions shall entitle Seller, without prejudice to any other remedies that may be available to Seller at law or in equity, to terminate Buyer's use of the Subscription(s) effective immediately.

Buyer further agrees and acknowledges that it shall not be entitled to any refund of any portion of the purchase price paid in respect of Subscription(s) cancelled by Seller pursuant to Seller's rights under this Section and/or the Terms of Use. Buyer's rights to use these Subscription will begin upon Seller's transmission to Buyer of Subscription link and end 12 months from this date unless otherwise terminated by Seller. In the event of any conflict between this Agreement and the Terms of Use, the Terms of Use shall control.

Xybix Systems, Inc. *Mona J*
 8207 SouthPark Circle
 Littleton CO 80120
 Phone: 303-683-5656
 Fax: 303-683-5454
 meghand



Quote Number: 29405

Quote Date: 9/9/2021
 Revision: A
 Orig Create Date: 9/8/2021
 Expires: 12/7/2021
 Opp #: 0025103

Quote

Terms: 50% DEP;40% INSTALL;10% PUNCH

Page: 1 of 3

<p>QUOTE TO: Acct: YORCOUALME York County EMA 149 Jordan Springs Rd Alfred ME 04002</p> <p>Phone: Email:</p>	<p>SHIP TO: York County EMA 149 Jordan Springs Rd Alfred, ME 04002 USA</p> <p>Salesperson: SUSANNE LOTTIE Phone: (207) 343-1229 Email: susannel@xybix.com</p>
---	--

Standard 2021-9 Price List
 EAGLE LINE
 * TAX EXEMPT

08.17.2021 R0: Drawing Creation. MND

Pandemic Freight Surcharge: This fee is the temporary upcharge we are experiencing for shipping related costs and delays

Line	Part Num	Desc	Qty	U/M	List Ea.	Disc. %	Disc. Price	Net Price
1.00	14145-BLK	Cable Pole 96" - Alum Black	4.00	EA	\$130.00	50.00 %	\$65.00	\$260.00
1.01	15335	Cable Pole Trim Kit Top and Bottom Aluminum Black	4.00	EA	\$32.00	50.00 %	\$16.00	\$64.00
2.00	C-14498-3D.	Adj. Table Worksurface - Straight Single Surface - 66W x 40D - Cable Management Included	3.00	EA	\$1,847.00	50.00 %	\$923.50	\$2,770.50
3.00	15701	L4 Table Base	3.00	EA	\$6,736.00	50.00 %	\$3,368.00	\$10,104.00
4.00	16747.	Monitor Mount 3 - Fixed on WS - Straight Single Surface - 66W x 40D 16676 - Std VESA Mount 2 HI 2 Knuckle Qty = 2 Total: \$1,720.00	3.00	EA	\$3,307.00	50.00 %	\$1,653.50	\$4,960.50
5.00	13729	Ext Monitor Cable 25' VGA High Quality Male/Female	12.00	EA	\$104.00	50.00 %	\$52.00	\$624.00
5.01	16275	Datadock2 - Single Surface - Cable Organizer - 8 USB, 1 RJ45	3.00	EA	\$885.00	50.00 %	\$442.50	\$1,327.50
5.02	11996	Ext. Cable USB Type A to Type A Extension & Booster 5M (16' 4")	8.00	EA	\$125.00	50.00 %	\$62.50	\$500.00
6.00	11792-BLK	Power Bar - 10 Outlet With Black Sticker	3.00	EA	\$170.00	50.00 %	\$85.00	\$255.00
6.01	11792-OR	Power Bar - 10 Outlet With Orange Sticker	3.00	EA	\$170.00	50.00 %	\$85.00	\$255.00

Xybix Systems, Inc.
 8207 SouthPark Circle
 Littleton CO 80120
 Phone: 303-683-5656
 Fax: 303-683-5454
 meghand



Quote Number: 29405

Quote Date: 9/9/2021
 Revision: A
 Orig Create Date: 9/8/2021
 Expires: 12/7/2021
 Opp #: 0025103

Quote

Terms: 50% DEP;40% INSTALL;10% PUNCH

Page: 2 of 3

7.00	CPNT.	Table Components	11	3.00 EA	\$519.00	50.00 %	\$259.50	\$778.50
		16709 - Task Lights - \$519.00						
10.00	12030-3D.	Return Worksurface - 30.25Wx23D	12	1.00 EA	\$491.00	50.00 %	\$245.50	\$245.50
10.01	12034-3D.	Return Worksurface - 54.25Wx28.25D	14	1.00 EA	\$822.00	50.00 %	\$411.00	\$411.00
10.02	12033-3D.	Return Worksurface - 18Wx36D	12	3.00 EA	\$656.00	50.00 %	\$328.00	\$984.00
11.00	15709	Cable Bridge Straight Left Side	15	2.00 EA	\$261.00	50.00 %	\$130.50	\$261.00
11.01	15710	Cable Bridge Straight Right Side	16	1.00 EA	\$261.00	50.00 %	\$130.50	\$130.50
11.02	13629-3D.	CPU Cabinet - Tech Tower 18Wx48H Left Access with Sliding Shelf	17	1.00 EA	\$2,490.00	50.00 %	\$1,245.00	\$1,245.00
11.03	13629-3D.	CPU Cabinet - Tech Tower 18Wx48H Right Access with Sliding Shelf	18	1.00 EA	\$2,490.00	50.00 %	\$1,245.00	\$1,245.00
11.04	13629-3D.	CPU Cabinet - Tech Tower 18Wx48H No Additional Access with Sliding Shelf	20	1.00 EA	\$2,490.00	50.00 %	\$1,245.00	\$1,245.00
12.00	11093-3D.	Drawer Pedestal - Mobile - Single - 16W - 6-6-12 Drawers 16W 18D	19	1.00 EA	\$1,330.00	50.00 %	\$665.00	\$665.00
12.01	11352-3D.	Drawer Pedestal - Fixed - Single - 18W - 6-6-12 Drawers 18W 22D - Ext. Back & Right	20	1.00 EA	\$1,404.00	50.00 %	\$702.00	\$702.00
12.02	11352-3D.	Drawer Pedestal - Fixed - Single - 18W - 6-6-12 Drawers 18W 22D - Ext. Back	21	1.00 EA	\$1,404.00	50.00 %	\$702.00	\$702.00
18.00	11099-3D.	Under Return End Support	22	4.00 EA	\$295.00	50.00 %	\$147.50	\$590.00
18.01	12235	Support - "L" Bracket 18"	23	5.00 EA	\$55.00	50.00 %	\$27.50	\$137.50
18.02	10005	Table Support leg	24	1.00 EA	\$97.00	50.00 %	\$48.50	\$48.50
18.03	14655	Wall Screw Anchor Kit	25	2.00 EA	\$15.00	50.00 %	\$7.50	\$15.00
90.00	16139	Installers Kit Eagle Line	26	3.00 EA	\$0.00	50.00 %	\$0.00	\$0.00
99.00	Other	Other Charges & Services	27	1.00 EA	\$0.00	0.00 %	\$0.00	\$0.00

Line (27) - Miscellaneous Charge -

Description	Ext. Price
1.) Freight	7,250.00
2.) Installation	6,886.50
3.) Pandemic Freight Surcharge	610.52

Xybix Systems, Inc.
 8207 SouthPark Circle
 Littleton CO 80120
 Phone: 303-683-5656
 Fax: 303-683-5454
 meghand



Quote Number: 29405

Quote Date: 9/9/2021
 Revision: A
 Orig Create Date: 9/8/2021
 Expires: 12/7/2021
 Opp #: 0025103

Quote

Terms: 50% DEP;40% INSTALL;10% PUNCH

Page: 3 of 3

Line	Part Num	Desc	Qty	U/M	List Ea.	Disc. %	Disc. Price	Net Price
		List Price Total:			\$61,052.00			
			Lines Total:					\$30,526.00
			Line Miscellaneous Charges					\$14,747.02
			Total:					\$0.00
			Taxes Total:					\$0.00
			Quote Total:					\$45,273.02

Note 1:
 All quoted taxes are estimated. Any applicable taxes, fees, permits, etc. must be added to this quote.

Note 2:
 Where installation is listed on quote it is based in non-union labor and on one trip for installation only. Client is responsible for coordination of Technicians and other Vendors/Contractors. Waiting time will be charged at the rate of \$75 per man hour straight time and \$115 per man hour for OT plus subsistence expenses.
 Additionally, this quote is based upon a remodel in an existing space and/or new building - completely finished with a Certificate of Occupancy. Any project where the General Contractor is still on the job is subject to additional charges.

We appreciate this opportunity to provide this quote. Our goal is to substantially improve working conditions for your valuable staff. We look forward to meeting with you to review this proposal in detail. In the meantime please don't hesitate to call us with any questions.



8207 Southpark Circle
 Littleton, CO 80120
 1.800.782.8519 F.303.686.5454
 www.xybix.com

Sales : Susanne Lottie

Email : SusanneL@xybix.com

Designer : Meghan Dineardi

Email : MeghanD@xybix.com

York County EMA
 149 Jordan Springs Rd
 Alfred, ME 04002



Opportunity: 0025103
 Drawing Name:
 COVER PAGE
 SHEET: 1 of 4
 SCALE: 12" = 1'-0"
 NOTE: This design & layout is the property of XYBIX Systems, Inc. & is not to be used in any written manner without express written permission by XYBIX Systems, Inc.
 Sign-Off Initials: REV 0

REV	DESCRIPTION	DATE	DSGN	MIND
0	Drawing Creation	08.17.21		

REVISIONS

Approval of the Client shall constitute approval of the drawings for contents, scope of work and all dimensions regardless by the Client as being necessary to the use of space, furnishings and equipment. Furniture orders, or product installation authorized by the Client from these documents, shall be interpreted by XYBIX as approval in full to these documents by the Client. Revisions after approval shall result in additional costs.

FINISH SELECTIONS

Panel Trim : N/A
 Panel Fabric Upper : N/A
 Panel Fabric Lower : N/A
 3D Laminate Counter : Dactor Rock, Concrete A017
 3D Laminate Drawer&Door Front : surf(x) Matte Luxe, Black 536745
 Melamine : Panolam Pluswood 905 Black Chamois
 Edgeband : Panolam Pluswood 905 Black match
 Handle : Eagle Silver

SIGN OFF APPROVAL: Furniture orders and product installation shall not proceed until the Client has given approval to these documents. Approval of the Client shall constitute approval of the drawings for contents, scope of work and all dimensions regardless by the Client as being necessary to the use of space, furnishings and equipment. Furniture orders, or product installation authorized by the Client from these documents, shall be interpreted by XYBIX as approval in full to these documents by the Client. Revisions after approval shall result in additional costs.

Signature: _____ Date: _____



8207 SouthPark Circle
Littleton, CO 80120
1.800.786.2610 F.303.683.5454
www.xybix.com

Sales : Susanne Lottie

Email : SusanneL@xybix.com

Designer : Meghan Dnardi

Email : MeghanD@xybix.com

York County EMA
149 Jordan Springs Rd
Alfred, ME 04002

Opportunity: 0025103

Drawing Name:
OVERALL VIEW

SHEET:
2 of 4

SCALE:
3/8" = 1'-0"

NOTE: This design & layout is the property of XYBIX Systems, Inc. & is not to be used in any written manner without express written permission by XYBIX Systems, Inc.

Sign-Off Initials: REV

0

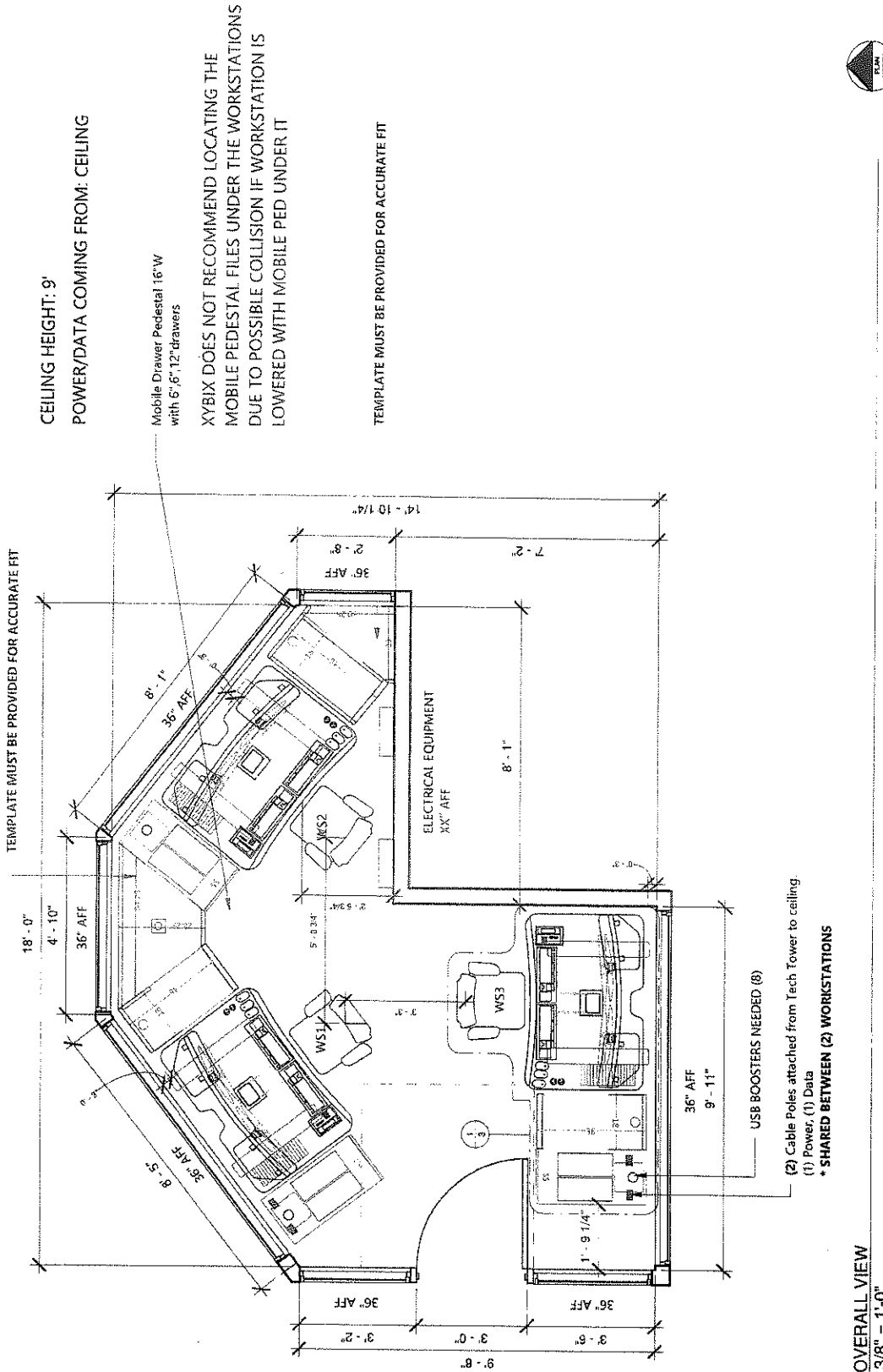

1 OVERALL VIEW
3/8" = 1'-0"

Xybix 66"x40" Single Surface Console with true sit to stand adjustment range of 22"-48" AFF, with L4 Table Base.

Control System (max. 2 Components)
 Task Light: (2) Dimmable lights with flexible mounting arm on keyboard surface

Data Dock - Keyboard surface cable organizer
 (8) USB Ports
 (1) CAT6 Port

"Rollvision" Monitor Mounting system capable of 10" of focal depth adjustment. Accommodates up to (2) 24" flat panel monitors on a single level. Additional mounts will be added to stack a second tier of (2) 24" monitors

Cable Management Bridge for cable organization from desk to CPU cabinet
NOTE: Not a shelf

Under fixed work surface. Drawer Pedestal 18"W with 6", 6", 12" drawers

(3) CPU Enclosure, 48" high, Tech Tower with front and side locking access doors,
 (2) easy access pullout shelves and
 (2) silent 45 CFM fans for active ventilation.
Maximum CPU dimension: (3) 18"H x 7.5"W x 18"D

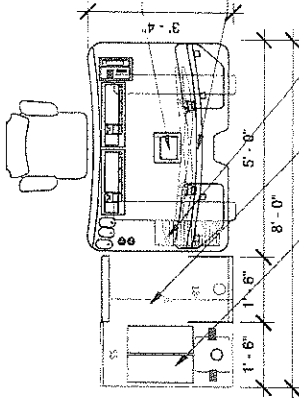

FINISHES

3D LAMINATE DRAWER/DOOR FRONT HANDLE
 3D LAMINATE COUNTER MELAMINE
 PANEL FABRIC COLOR

COLOR COLOR COLOR SILVER

CONCEPTUAL IMAGES. REFER TO ACTUAL COLOR SAMPLES FOR EXACT COLOR REPRESENTATION



① TYPICAL WORKSTATION
 3/8" = 1'-0"

MONITOR EXTENSION CABLE CONNECTIONS

MONITOR EXTENSION CABLES PER POSITION Position Type TYPICAL WORKSTATION

CABLE TYPE	QTY NEEDED	DESCRIPTION	DVI-D	DVI-I	HDMI	Display Port	USB	AUDIO
	4 EA.	VGA Male / Female Extension Standard connection for monitors	DVI-D Male / Female Extension Typical for Hi-Resolution	DVI-I 30' Max Length Male / Female Extension Typical for Hi-Resolution	HDMI Male / Male Extension Typical for Hi-Resolution	Display Port Male / Male Extension Typical for Hi-Resolution	USB Keyboard / Mouse	AUDIO Typical for Speakers

DATA DOCK

For Keyboard, Mice and Phone connection. Data Dock USB Cables are exclusively sold through XybiX only.

Standard Data Dock System will include:

- (1) CAT6 coupler
- (4) Dual-USB Ports (8 ports total)

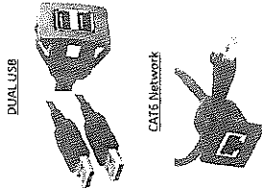

STANDARD SHOWN

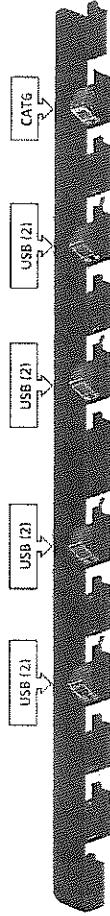

OPTIONAL ITEMS

ADDITIONAL DATA DOCK CABLES

Indicate the number of each cable to be included **in addition** to the standard Data Dock

NOTE: These cables will be charge separately
NOTE: There are only 5 available spaces for these options



QTY _____



QTY _____

If different cable connector types are required it is your responsibility to contact your designer or sales rep.

*** You agree that any changes to this order following receipt of sign-off drawing and PO may result in additional cost that will be expensed to the client ***

Signature: _____ Date: _____



8207 SouthPark Circle
Littleton, CO 80120
1.800.762.8210 F.203.582.544
www.xybiX.com

Sales: Susanne Lotfie

Email: Susanne.Lotfie@xybiX.com

Designer: Meghan Dineff

Email: MeghanD@xybiX.com

York County EMA
149 Jordan Springs Rd
Alfred, ME 04002

Opportunity: 0025103

Drawing Name:

CABLE SHEET

SHEET: SCALE:

4 of 4

NOTE: This design & layout is the property of XYBI, Systems, Inc. & is not to be used in any written manner without express written permission by XYBI, Systems, Inc.

Sign-Off Initials: REV

0

***SOUTHERN MAINE COMMUNICATIONS SERVICE
AIRPORT INDUSTRIAL PARK, 9 KOSTIS LANE
P.O. BOX 924
SANFORD, MAINE 04073***

VOICE (207) 324-6755 FAX (207) 324-6766

--ESTIMATE--

TO: Sanford Regional Communications
ATTN: Bill Tower
DATE: July 8, 2021
RE: Adding 3 backup radio console positions at YCEMA

--OVERVIEW--

Provide and install 3 new Zetron touchscreen radio consoles (same type as at SRCC to allow near identical operation) and common controller (server) along with associated control radios and antennas at YCEMA. This will be utilized to provide back-up communications for Berwick/South Berwick Police and Fire Channels, YCSO Primary channels, and YC Fire Primary channels. Customer to provide radio console furniture to allow placement of touchscreen and audio panel. Provide and install 2 multi-channel local control radios and connect radios to console system.

--MATERIALS--

9) Dispatch radio control base stations with RF filtering
on both TX and RX as required to prevent internal interference.

Radio channels are as listed:

(3) YCSO Primary channels

(2) BER/SB PD and Fire channels

(4) YC FIRE 1, 2, 3, watertank

@ 14,500.00 ea

\$ 130,500.00

2) Multi-channel radios near consoles (one VHF, one UHF)	@ 6,750.00 ea	\$ 13,500.00
9) Control radio antenna systems and lightning protection	@ 4,500.00 ea	\$ 40,500.00
2) Multi-channel radio antenna systems	@ 5,500.00 ea	\$ 11,000.00
1) Zetron Integrator RD consoles (3 positions) with M4020 control (complete Zetron materials list available upon request)		\$ 229,955.00

--INSTALLATION--

1) Installation and set-up of all listed materials at YCEMA		\$ 54,000.00
---	--	--------------

TOTAL AMOUNT: \$ 479,455.00

+ 45,273.02

524,728.02

Best Regards,

Jeff Kostis

ZETRON CONSOLE PRICING FOR SRCC AT YCEMA 7-8-21

1) 905-0309 3 POSITION BUNDLE		\$ 141,720.00
3) 930-0026 EXTENDED PAGING	@ 1,369.00	4,107.00
3) 930-0051 MDC OPTION	@2,767.00	8,301.00
3) 930-0187 PAGING LICENSE	@2,304.00	6,912.00
3) 400-0205 AUDIO PANEL ENCLOSURE	@ 829.00	2,487.00
3) 950-1414 GOOSE NECK MIC	@ 827.00	2,481.00
3) 802-0092 M4217 PWR SUPPLY	@ 154.00	462.00
1) 950-9820 CHANNEL CARD		5,738.00
2) 950-0293 AUX/I-O RELAY CARD	@ 2,436.00	4,872.00
7) 950-9199 PROTECTED PUNCH BLOCKS	@ 1,019.00	7,133.00
9) 709-0004 25 PAIR CABLES	@ 107.00	963.00
3) 950-1270 19" TOUCHSCREEN	@ 1,589.00	4,767.00
2) 802-0330 RACK MOUNT UPS	@ 2,274.00	4,548.00
3) 802-0329 DESKTOP UPS	@ 412.00	1,236.00
3) 950-0083 19" EQUIP RACK	@ 3,076.00	9,228.00
1) MISC MATERIALS		25,000.00
TOTAL ZETRON ONLY MATERIALS		\$ 229,955.00

370 MAIN STREET
SOUTH BERWICK, ME 03908
207 384 2049
lasselarchitects.com



York County
45 Kennebunk Road
Alfred, Maine 04002

October 22, 2021

RE: Bid review and recommendation for the EMA renovation expansion.

Attention: Gregory Zinser, County Manager

Dear Greg,

Attached is the revised proposal and bid estimate with Inclusions and clarifications from Allied Cook Construction.

We have gone over the proposal by line item and reviewed the clarifications. We feel this represents a fair price. As you know the cost of materials and labor has taken a dramatic increase during COVID. This increase is not out of line with other projects we are bidding especially mechanical, lumber, and thermal and moisture protection. In addition, the labor costs for several trades are about 50% higher than current labor rates to meet Davis Bacon.

Allied Cook has gone out to several vendors for each trade. With this information and the reality of our current economics we approval this proposal.

Let me know if you have any questions.

Thank You,

Michael W. Lassel AIA LEED AP
President

Attachments: Allied Cook Construction; Concept proposal with line-item bids and letter of Inclusions and Clarifications.

Inclusions & Clarifications

1	This budget is based upon the Lassel Architects Specifications dated August 13, 2021, Drawings dated August, 2021, and ammended by Addendum #1 dated 09.02.21. Our pricing is based on the plans and industry standards.
2	This budget proposal is based on a 6 month project.
3	Existing walls are to be left as is. No insulation or other products besides paint are included here.
4	Doors are key only, fobs and/or pads are excluded.
5	FF&E, cubicles and all furniture are excluded, to be by Owner.
6	ACT has been carried in lieu of drywall ceilings per Addendum #1.
7	Minor floor leveling is included. The space has not been field measured. Any significant floor leveling or gypcrete is excluded.
8	No Sprinkler System is included.
9	CMP/Utility fees are excluded.
10	Electrical pricing is based upon the Addendum #1 superceding the drawing for scope and intent.
11	The electrical price and entire scope includes the dispatch room as part of this project.

Exclusions

1	Payment and Performance Bond.
2	Builders Risk Insurance - by owner.
3	Power and water costs for construction use to be supplied by the owner, temporary utility consumption is excluded.
4	Permanent power consumption costs.
5	Materials testing.
6	Special inspections.
7	LEED certification and commissioning.
8	All utility company fees.
9	Costs to remove unsuitable soils below grade.
10	Seismic bracing.
11	FSC wood requirements.
12	Expansion Joints.
13	Custom colors unless specified.
14	Mitigation of excessive slab moisture content.
15	Commissioning agent.
16	Sprinkler System and Fire pumps.
17	Access Control and Card Readers are excluded.
18	Security, Voice, Data, Phone Systems are excluded.
19	Owner Furnishings i.e. all furniture, desks, tables, file storage units, copiers, printers, computers, TV's.
20	Overtime hours, off-hours work and weekend work are excluded.

Allowances

1	Dumpster Allowance:	\$15,000.00
2	Landscaping Patch & Repair Allowance:	\$10,000.00
3	Concrete Cutting & Patching Allowance:	\$6,834.00
4	Masonry Patching Allowance:	\$5,000.00
5	Metal Railing under Roof Overhang Allowance:	\$10,000.00
6	Insulation Allowance:	\$5,500.00
7	EIFS Siding Allowance:	\$58,575.00
8	Patch Vapor Barrier Allowance:	\$1,500.00
9	Interior Signage Allowance:	\$1,200.00

Alternates

1	Re-roof entire low-roof around existing building:	\$75,619.00
---	---	-------------



NO.	ITEM	AMOUNT		DIVISION TOTALS
1	GENERAL CONDITIONS			6 Months
	a. General Conditions	\$ 165,000		
	b. Winter Conditions - NIC	\$ -		
	c. Dumpster - ALLOWANCE	\$ 15,000		\$180,000
2	SITE WORK			
	a. Landscaping repair - Allowance	\$ 10,000		
	b. Demolition	\$ 47,861	Envirovantage	\$57,861
3	CONCRETE			
	a. Concrete cutting & patching - Allowance	\$ 6,834		\$6,834
4	MASONRY			
	a. Masonry Patching - Allowance	\$ 5,000		\$5,000
5	STEEL			
	a. Lintels above new openings	\$ 1,020		
	b. Misc. Metals - Railing above stairs (exterior) - Allowance	\$ 10,000	McBrady	\$10,000
6	CARPENTRY			
	a. Rough Carpentry, Framing & General Project Labor	\$ 100,912		
	b. Finish Carpentry	\$ 24,800	Pond Cove	\$125,712
7	THERMAL & MOISTURE PROTECT.			
	a. EIFS siding - Allowance	\$ 58,575		
	b. Patch/tie-in vapor barrier - Allowance	\$ 1,500		
	c. Insulation - Allowance	\$ 5,500		
	d. Roofing	\$ 89,917	Glidden	
	e. Caulking & Sealants	\$ 1,840		\$157,332
8	DOORS & WINDOWS			
	a. Doors, Frames, & Hardware	\$ 31,464	Loranger	
	b. Aluminum Storefronts	\$ 10,800	Glass Solutions	
	c. Windows	\$ 16,307	Pinnacle	\$58,571
9	FINISHES			
	a. Drywall Systems	\$ 47,090	Godin Assoc.	
	b. Acoustical Ceilings	\$ 23,300	Ace Acoustics	
	c. Flooring	\$ 31,920	Paul White	
	d. Paint	\$ 11,021	FA Gray	\$113,331
10	SPECIALTIES			
	a. Interior Signage - Allowance	\$ 1,200		
	b. Fire Extinguishers	\$ 1,300		\$2,500
11	EQUIPMENT	(no work)		
12	FURNISHINGS	(no work)		
13	SPECIAL CONSTRUCTION	(no work)		
14	CONVEYING SYSTEMS	(no work)		
15	MECHANICAL			
	a. Mechanical Systems	\$ 191,427	ABM	
	b. Fire Sprinkler Systems - NIC	\$ -		\$191,427
16	ELECTRICAL			
	a. Electrical Systems	\$ 79,950	Martineau	\$79,950
		\$ 989,538		
	Building Permit Costs - NIC	\$ -		
		\$ -	\$ 989,538	
	Builder's Risk Insurance		By Owner	
	General Liability	\$ 9,895		
	Performance & Payment Bond	NA		
		\$ 9,895	\$ 999,433	
	Construction Contingency: 5.0%	\$ 49,972		
		\$ 49,972	\$ 1,049,405	
	Construction Management Fee:	\$ 45,000		
		\$ 45,000	\$ 1,094,405	
	TOTAL (3,078 SF)	\$ 1,094,405		\$355.56 /SF