

1 **COMMISSIONERS WORKSHOP ON AMERICAN RESCUE PLAN FUNDING**

2  
3 **October 6, 2021**

4  
5  
6 *YORK,ss*

7  
8 At a Workshop of the County Commissioners of the County of York, begun and  
9 holden at the York County Government Building in Alfred, within and for the County of York,  
10 being held on Wednesday, October 6, 2021 A. D. at 3:00 P. M.

11  
12  
13 **COMMISSIONERS PRESENT:**

14  
15 Richard R. Dutremble  
16 Richard Clark  
17 Robert Andrews  
18 Allen Sicard  
19 Donna Ring  
20

21  
22  
23 County Manager Gregory Zinser and Deputy County Manager Linda Corliss were present at the  
24 meeting.

25  
26 **YOU ARE INVITED TO RISE AND SALUTE THE FLAG OF THE UNITED STATES**

27  
28  
29 **10-06-21 ITEM**

30  
31  
32 **1 PUBLIC COMMENT(S) ON ANY ITEM(S)**

33 None

34  
35 **2 TO HEAR FROM THE FOLLOWING:**

- 36 a. Donna Dwyer-My Place Teen Center- County Manager Zinser explained  
37 that he and the Commissioners visited the teen center in Westbrook. The  
38 request is for \$1.5 million. Their packet is attached as record.  
39 Donna Dwyer, President and CEO of MPTC addressed the Board and explained  
40 the history of the Center.  
41 Commissioner Ring commented that she was extremely impressed with the  
42 Center (in Westbrook) that she visited. She added that it would be a wonderful  
43 center for York County.  
44 Guy Gagnon from Southern Maine Affordable Housing addressed the Board.  
45 He explained that they are an "arm" of the Biddeford Housing Authority and  
46 that they are a non-profit and have their own Board. He assured the Board that  
47 funds will be managed efficiently and accurately.

48 Commissioner Dutremble stated that he also had visited the facility in  
49 Westbrook and it was well done. He added that as a former employee of the  
50 City of Biddeford, he knows the Biddeford Housing Authority does a great job.  
51 Commissioner Sicard commented that he saw that the Center has received  
52 \$400,000 in donations. He asked Mr. Gagnon if he still feels confident (about  
53 the project)?

54 Guy Gagnon responded, yes. He continued that they always try to hire local  
55 people and have lots of buy in from the community.

56 County Manager Zinser asked Donna Dwyer to explain the regional impact the  
57 Center will have.

58 Donna Dwyer explained that My Place Teen Center has been in Cumberland  
59 County for almost 23 years. We impact a dozen other towns and cities in the  
60 greater Portland area. Ms. Dwyer added that the same will be true once they  
61 open in Biddeford. Any kid is welcome. During COVID, she explained, the  
62 Center was one of the non- profits that never shut down. Within 48 hours, we  
63 galvanized our staff. We turned into a mobile food pantry and were curbside.  
64 Donna Dwyer stated that they served hot meals for 9 months for free. We  
65 served anyone a meal free.

66 Reverend Tim Higgins, Chairperson of the Board of Directors at My Place Teen  
67 Center commented regarding Donna's leadership over the past 10 years and her  
68 ongoing commitment. He added that some, including himself have been on the  
69 Board of Directors for 10-12 years.

70 Commissioner Sicard commented that sometimes when the Board makes a large  
71 investment we take a seat on the Board. Are you open to that?

72 Reverend Higgins responded, absolutely. We would love that.

73 Commissioner Ring asked Donna Dwyer with the funding from ARP, when is  
74 your projected date of opening? Donna Dwyer replied that 2023 would be a  
75 target date.

76 County Manager Zinser pointed out to all of the participants that they don't  
77 have to stay but that the Commissioners cannot make any decisions until the  
78 meeting. He continued that he doesn't know if they will be voting tonight but  
79 that there will be a process and no one will just be handed a check.

80 We haven't gotten that far yet as to how we will fund the projects we approve,  
81 stated the County Manager.

- 82
- 83 b. Emily Flinkstrom-Fairtide- County Manager Zinser introduced Emily  
84 Flinkstrom, Executive Director of Fairtide who explained that Fair Tide is a  
85 non- profit located in Kittery ME that provides housing for those who are  
86 homeless or at risk to be homeless. She went on to explain that they own  
87 property and work with landlords to provide housing and have been in existence  
88 for around for 23 years, expanding in the last 5 years. Her proposal is two part:  
89 to be able to provide a resource hub of social services as well as affordable  
90 housing. This vision started about 3 years ago when social service agencies got  
91 together, stated Ms. Flinkstrom. The current system is disjointed and not at all  
92 client-friendly. This vision would be for a household in need to go to just one  
93 place. This, explained Ms. Flinkstrom, is in line with some Statewide services  
94 that are happening now. We envision a shared office or two for mental and  
95 physical health and dental agencies. She added that she does have letters of  
96 support from many of these agencies. Fairtide assists over 1,000 households a  
97 year but not sure how many of these are duplicate numbers. She continued that  
98 it is intimidating to try and figure out how to get help. With COVID many more

99  
100  
101  
102  
103  
104  
105  
106  
107  
108  
109  
110  
111  
112  
113  
114  
115  
116  
117  
118  
119  
120  
121  
122  
123  
124  
125  
126  
127  
128  
129  
130  
131  
132  
133  
134  
135  
136  
137  
138  
139  
140  
141  
142  
143  
144  
145  
146  
147  
148  
149

households need help. We have created a shared application for those impacted by COVID. We are asking for \$750,000 to acquire a site. We have one in mind and we have been talking with the owners who also own a non-profit. Ms. Flinkstrom continued that they would have to spend some additional money to outfit the property for their needs. All of our agencies already pay rent and have overhead, so shared space would save all money.

The affordable housing would be administered through Maine Housing. We would be asking for money for site acquisition. Community Housing of Maine would be a partner, Ms. Flinkstrom stated. She continued that they have been working with them for four years to try and find a potential site.

Commissioner Clark replied that he is not entirely clear where the other funds would be coming from and that he would want to see that before done. These are the issues that he would like a lot more information on. He added that he would need more detail on what other partners would be contributing.

Ms. Flinkstrom commented that the hope is that they would have a site acquired within a year and also be raising the funds while the property is developed. She informed all that they will be losing the current Fairtide site so they are motivated to find a new site. As far as the affordable housing piece, the timeline is a bit longer as they would be counting on tax credits. Ms. Flinkstrom stated that she would be happy to write that up with more detail.

Commissioner Ring commented that she was not clear on what Ms. Flinkstrom is asking for.

Emily Flinkstrom responded, to acquire a site. One site we are looking at could work for both pieces. Both of those projects could come to fruition. For the resource hub, they are also exploring a different site and the \$750,000 would be used to purchased that.

Commissioner Sicard stated that the document provided stated an amount of \$3 million for site acquisition.

Ms. Flinkstrom explained that is for the site that could work for both. We are also talking to potential investors.

Commissioner Ring asked for Ms. Flinkstrom to provide the Commissioners with a little more detailed sheet as there really isn't enough information here for them to make a decision.

Commissioner Clark asked Emily when she could have the information for the Commissioners. She replied that she can have it for them for their next meeting. Commissioner Clark added that he doesn't want Ms. Flinkstrom to have to let us know in public where the property is.

Emily Flinkstrom replied, yes, neither of the properties are on the market.

Commissioner Clark replied that they could meet in executive session for that.

County Manager Zinser asked Ms. Flinkstrom what towns Fairtide impacts?

She replied, Kittery, Eliot, South Berwick, York, and to some degree, Berwick.

County Manager Zinser asked Ms. Flinkstrom if she had approached any of those towns for funding as they also received ARP funds? She replied, not yet.

Commissioner Clark requested that Ms. Flinkstrom be put on the agenda for an update as he thinks time is of the essence.

Commissioner Sicard reminded all that they have other projects that they have already discussed that they need to revisit.

- c. Transportation discussion with Barbara Crider and Thomas Reinauer from YCCAC, Paul Schumacher from SMRPDC and Al Shutz from STSolutions. Paul Schumacher addressed the Board and stated that his organization doesn't

150 have a dollar proposal but it's (transportation) a critical issue in the region. We  
151 are working on a number of different projects in the area looking at transit. We  
152 are finishing project right now with PNSY and the Town of Kittery. Sanford  
153 has the highest number of residents that commute to the Shipyard. Waterboro,  
154 Shapleigh and Alfred also have a lot of residents who work at the PNSY.  
155 Transportation in York County is a fragmented system. The new courthouse in  
156 Biddeford, stated Mr. Schumacher, will have there will be an issue to getting  
157 people to court.  
158 Tom Reinhauser, Director of Communication at York County Community  
159 Action addressed the Board and stated that this is a broad topic. A lot of the  
160 services they provide, he explained, depend on the funding sources they  
161 receive. WAVE provides (transportation) services that are more flexible than a  
162 route schedule. Commissioner Clark stated that his observation is that the  
163 Board has talked about wanting to make a one time investment. He continued  
164 for example, a fleet improvement or something as I do not think the county  
165 wants to be a part of an annual investment. This State has the oldest average  
166 age in the country. We have a significant amount of rural people who want to  
167 age in place. It will become more and more difficult for them to drive to the  
168 doctors and grocery store, etc. It is a serious issue. Commissioner Clark stated  
169 that he has heard of programs that can't find drivers. He asked Mr. Reinhauser  
170 if this was an issue?  
171 Mr. Reinhauser replied that they are constrained and it has been a challenge.  
172 He added that they have had to curtail services because they don't have enough  
173 drivers.  
174 Commissioner Ring stated that rehabilitation and housing, is of no value unless  
175 we can get people there. If they do not have transportation, they can't continue  
176 with their counseling. She suggested that maybe they could all get together  
177 and come up with a plan for the rural areas, too.  
178 Commissioner Sicard stated that he agreed with Commissioner Ring.  
179 Al Shutz, business agent for STSolutions addressed the Board and referenced a  
180 PowerPoint he had given the Commissioners. His transportation system would  
181 be run by York County to get people in rural areas. In order to deploy enough  
182 busses to meet countywide demand, 6 to 8 buses would be needed, commented  
183 Mr. Shutz. We would need to find out where the underserved areas are and  
184 have a flexible system with buses running through. Commissioner Dutremble  
185 asked what the cost of the buses would be. Mr. Shutz replied that he would  
186 lease them. Commissioner Dutremble asked who would be responsible for  
187 paying the employees? We have to spend the (ARP) money by 2024. We need  
188 a plan in front of us, stated Commissioner Dutremble.  
189 Commissioner Sicard asked Mr. Shutz if \$2.5 to \$2.7 million was an accurate  
190 estimate?  
191 Al Shutz replied that was a rough estimate and that he could pare it down to  
192 work with the County. He added that they could coordinate with other  
193 companies that already have transportation like YCAC.  
194 Paul Schumacher asked when do you need to spend the money?  
195 County Manager Zinser replied that there area lot of issues here. The money  
196 needs to be committed by 12-31-2024 and needs to be spent by 12-31-2026.  
197 The County Manager added that other questions include: Can we buy non-  
198 profits vehicles instead? Who needs to be at this conversation to make sure  
199 everyone is served? With STS's proposal, the county would run the program.  
200 He asked the Commissioners, if they want the County to be a transit provider?

201  
202  
203  
204  
205  
206  
207  
208  
209  
210  
211  
212  
213  
214  
215  
216

Or do you want to fund the busses? A broader scope of people need to be here, stated the County Manager.

Commissioner Ring stated that she felt the county was not interested in going into a transit business.

Paul Schumacher responded that there are consultants who are working on transit with the shipyard project. There has to be proposals and ideas. He added that he was just trying to figure out timing.

Commissioner Sicard stated that Al Shutz has experience with Biddeford, OOB and Saco and Al brought Scarborough in. There are models out there where you bring in a larger governing system.

Tom Reinauer stated that his agency is also available to talk about providing more services. He added that long term sustainability is the hard part.

**ADJOURN**

Workshop adjourned at 4:30 p.m.

DRAFT

1 **COMMISSIONERS MEETING**

2 **October 6, 2021**

3  
4  
5 *YORK,ss*

6  
7 At a regular meeting of the County Commissioners of the County of York, begun and  
8 holden at the York County Government Building in Alfred, within and for the County of York,  
9 being held on Wednesday, October 6, 2021 A. D. at 4:30 P. M.

10  
11  
12 **COMMISSIONERS PRESENT:**

- 13
- 14 Richard R. Dutremble
- 15 Richard Clark
- 16 Robert Andrews
- 17 Allen Sicard
- 18 Donna Ring
- 19
- 20
- 21

22 County Manager Gregory Zinser and Deputy County Manager Linda Corliss were present at the  
23 meeting.

24  
25  
26 **YOU ARE INVITED TO RISE AND SALUTE THE FLAG OF THE UNITED STATES**

27  
28 **10-6-2021 ITEM**

29  
30 **1 PUBLIC COMMENT(S) ON ANY ITEM(S)**

31 Janet Drew addressed the Board and stated that she had listened to Penobscot  
32 County Commissioners' meeting yesterday and was impressed to hear 30  
33 organizations that got together to talk about the ARPA funding and what they do  
34 on a shoe- string. She added that a lot of these little organizations don't have grant  
35 writers. The people who have the least responses but the most impact from  
36 COVID need help away from the jail, stated Ms. Drew. She commented that she  
37 sees a lot of new hires on the agenda and asked if they will be funded through  
38 ARPA funds or part of the County budget? Ms. Drew also asked if there are any  
39 multi county meetings where you are talking to other officials about things that  
40 need to be done in their counties.

41 County Manager Greg Zinser answered that the positions that are on the agenda  
42 for hiring approval are currently budgeted positions from a couple of years ago.  
43 Fire instructors and corrections officers are all general funding. County Manager  
44 Zinser stated that he met with other counties Monday at 1:00 to see what other  
45 counties are up to. Maine County Commissioners Association and other county  
46 groups are also having conversations.

47  
48 **2 TO APPROVE THE MINUTES OF THE FOLLOWING MEETINGS:**

- 49 a. Workshop of September 15, 2021- Commissioner Sicard motioned to approve  
50 the minutes. Commissioner Clark seconded the minutes. Vote 5-0.  
51  
52 b. Regular meeting of September 15,2021 – Commissioner Clark motioned to  
53 approve the minutes. Commissioner Sicard seconded the motion. Vote 5-0.

54 **3 TO APPROVE TREASURER’S WARRANTS**

- 55 a. Warrants to be approved on September 22, 2021 in the amount of \$232,537.92  
56 Commissioner Clark. Commissioner Sicard seconded the motion. Vote 5-0.  
57 b. Warrants to be approve on September 29, 2021 in the amount of \$556,803.28  
58 Commissioner Clark motioned to approve the warrant. Commissioner Sicard  
59 seconded the motion. Vote 5-0.  
60

61 **4 TO HEAR ANY REPORTS FROM THE COUNTY**  
62 **COMMISSIONERS**

63 Commissioner Clark informed all that he attended by ZOOM, the Coastal  
64 Counties Workforce Inc. annual meeting. He explained that this organization works  
65 with folks who have difficulty with employment issues. Commissioner Clark  
66 added that it is impressive the number of people they have helped. He also  
67 mentioned that Commissioner Ring, County Manager Zinser and he visited the  
68 Teen Center in Westbrook a couple of weeks ago. He reminded all that they are  
69 requesting ARPA funds to build a similar center in Biddeford. Commissioner  
70 Clark stated that he was extremely impressed and that the Center was of a level that  
71 he did not expect.

72 Commissioner Ring agreed and stated that the center far exceeded her expectations.  
73 Commissioner Dutremble stated that he and Commissioner Sicard had visited the  
74 Center previously and both were also impressed.

75 Commissioner Andrews added that he had also visited and witnessed children  
76 doing their homework and being taught to play instruments. He continued that  
77 children were also being fed and that the place was immaculate.  
78

79 **5 TO HEAR ANY REPORTS FROM THE COUNTY MANAGER**

80 No formal reports  
81

82  
83 **6 NEW BUSINESS**

- 84 a. H.R. Director Linda Corliss to request the hiring of the following persons:  
85 i. hiring of Joan Fox in the position of part time legal secretary in the D.A.’s  
86 office with a start date of October 12, 2021- H.R. Director Corliss explained  
87 that this position was vacated by a resignation.  
88 Commissioner Clark motioned to approve the hiring of Joan Fox.  
89 Commissioner Ring seconded the motion. Vote 5-0.  
90 ii. hiring of Robert Martin in the position of Fire Instructor I-EMA Reserve with  
91 a start date of October 6, 2021-  
92 Commissioner Clark motioned to approve the hiring of Robert Martin.  
93 Commissioner Sicard seconded the motion. Vote 5-0.  
94 iii. hiring of Ray Legendre in the position of Fire Instructor I-EMA Reserve with  
95 a start date of October 6, 2021-  
96 Commissioner Clark motioned to approve the hiring of Ray Legendre.  
97 Commissioner Sicard seconded the motion. Vote 5-0.  
98 iv. hiring of Dave Hamel in the position of Fire Instructor II-EMA-Reserve with

99  
100  
101  
102  
103  
104  
105  
106  
107  
108  
109  
110  
111  
112  
113  
114  
115  
116  
117  
118  
119  
120  
121  
122  
123  
124  
125  
126  
127  
128  
129  
130  
131  
132  
133  
134  
135  
136  
137  
138  
139  
140  
141  
142  
143  
144  
145  
146  
147  
148  
149

- a start date of October 6, 2021-  
Commissioner Clark motioned to approve the hiring of Dave Hamel.  
Commissioner Sicard seconded the motion. Vote 5-0.
- v. hiring of Joshua Perry in the position of Fire Instructor II-EMA-Reserve with a start date of October 6, 2021-  
Commissioner Clark motioned to approve the hiring of Joshua Perry.  
Commissioner Sicard seconded the motion. Vote 5-0.
- vi. hiring of Pat Sarto in the position of Fire Instructor II-EMA Reserve with a start date of October 6, 2021-  
Commissioner Clark motioned to approve the hiring of Pat Sarto in the position of Fire Instructor II-EMA Reserve. Commissioner Sicard seconded the motion. Vote 5-0.
- vii. hiring of Aaron Leary in the position of full-time Corrections Officer in the Sheriff's Office with a start date of November 1, 2021-  
Commissioner Clark motioned to approve the hiring of Aaron Leary in the position of full-time corrections officer. Commissioner Sicard seconded the motion. Vote 5-0.
- viii. hiring of Natalia Morneau in the position of reserve Corrections Officer in the Sheriff's Office-  
Commissioner Clark motioned to approve the hiring of Natalie Morneau in the position of reserve Corrections Officer. Commissioner Sicard seconded the motion. Vote 5-0.
- b. Major Paul Mitchell to request award of bid for six vehicle purchases-  
Commissioner Ring asked if the vehicles are all for patrol? Major Mitchell stated, yes, they are part of the every 4 year rotation and were last replaced in 2016 and 2017. Commissioner Ring asked if any are going to contract towns? Major Mitchell replied, no, the towns buy their own cars. Commissioner Ring asked how many patrol positions there were to which Major Mitchell replied, 27 patrol positions.  
Commissioner Sicard commented that Arundel Ford is a York County business even though they are a bit more. He added that he tries to shop in York County whenever we can as they are a tax payer.  
Commissioner Ring agreed.  
Commissioner Sicard motioned to accept Arundel Ford's auto bid of (6) vehicles at a cost of \$33,069.00 each.  
Commissioner Ring seconded the motion. Vote 5-0.
- c. Seek Commissioner approval on changes to County's purchasing policy-  
The County Manager explained to the Commissioners that they received in their meeting packet information with a draft policy, correspondence from our attorney and documents from Sourcewell that is a cooperative purchasing arrangement. Commissioner Ring asked will we be ruling out some of our smaller vendors in York County being allowed to bid? County Manager Zinser stated it is national and it can be local. He asked Facilities Manager, Rick deRochemont if he had any information to add. Facilities Manager deRochemont explained that with the Sourcewell program, anyone can bid. They do the bidding for us. He added that Corey Jensen from Sourcewell is on the line if we have questions.  
Commissioner Ring clarified by asking if this policy is specifically for Sourcewell?



150  
151  
152  
153  
154  
155  
156  
157  
158  
159  
160  
161  
162  
163  
164  
165  
166  
167  
168  
169  
170  
171  
172  
173  
174  
175  
176  
177  
178  
179  
180  
181  
182  
183  
184  
185  
186  
187  
188  
189  
190  
191  
192  
193  
194  
195  
196  
197  
198  
199  
200

County Manager Zinser replied that it allows us to use other entities that engage in cooperative purchasing.  
Commissioner Ring asked if there is a maximum or minimum amount before they would bid for us?  
County Manager Zinser replied, no.  
Commissioner Ring asked when do we determine when we would use this?  
County Manager Zinser replied that there can be a conversation to decide.  
Commissioner Clark stated that he can support this but that he wants to be sure we continue to advertise locally so local vendors can be aware of county needs as opposed to have to go to a bulletin board online. He continued that he understands the advantage of national exposure and understands that it might not be York County companies who get the job but that he doesn't want to cut local folks out of the process.  
County Manager Zinser responded that can be incorporated. He added that this policy was reviewed by our legal counsel and prepared with counsel's suggestions.

Commissioner Clark motioned to approve the changes to allow for cooperative purchasing but that he wants the County Manager to bring back some kind of language (work with our legal counsel) that assures that any bid also be posted within the county as well. Commissioner Andrews seconded the vote. Vote 5-0.

- d. Discussion on hiring practices-County Manager Zinser asked for a motion to table this item.  
Commissioner Ring motioned to table this item. Commissioner Andrews seconded the motion. Vote 5-0.
- e. County's annual Spirit of America award ceremony-  
Commissioner Clark stated that it would be his preference to do it in person but that is not possible so he would suggest ZOOM or something similar.  
County Manager Zinser suggested this be held during the second meeting in November.  
Commissioner Clark suggested this event be held at 3:00.  
Commissioner Dutremble stated that we need to notify all the towns so they can be on ZOOM.
- f. Seek Commissioner approval of MSEA contract-  
County Manager Zinser stated that there have been no changes in the contract since he informed the Commissioners about it near the end of August.  
The County Manager reviewed the changes to the new contract.  
Commissioner Ring asked if the position descriptions were in the contract?  
County Manager Zinser replied that he didn't know.  
Commissioner Clark moved to approve the MSEA contract. Commissioner Sicard seconded the motion. Vote 4-1 with Commissioner Ring opposed.  
County Manager Zinser informed all that the retro active pay will take some time to complete. He added that it could take 2- 3 weeks.
- g. Any ARPA related discussions/decisions-  
County Manager Zinser stated that he had two things to talk about with the Board. At a prior meeting, he explained that he informed the Board that he

201 was working with the sewer district in regards to a feasibility study and other  
202 engineering and planning and therefore is requesting that the Board authorize  
203 \$400,000 so we can begin to move forward with other projects.  
204 Commissioner Clark motioned to appropriate \$400,000 for further studies.  
205 Commissioner Ring seconded the motion. Vote 5-0.  
206 The next item is the Clinical Director for which the County Manager has a  
207 draft solicitation for the Commissioners.  
208 Commissioner Ring asked if this (position) will be part time and also,  
209 confirmed that this is an RFP, not a hiring. The County Manager replied,  
210 correct.  
211 Commissioner Clark moved to authorize the County Manager to post the RFP  
212 to solicit proposals. Commissioner Sicard seconded the motion. Vote 5-0.  
213  
214 Commissioner Clark stated that he is impressed enough by the proposal of My  
215 Place Teen Center and seeing the Westbrook facility that he is ready to go  
216 forward to grant their request with the understanding we need to work out how  
217 the funds are dispersed in the amount of up to \$1.5 million of ARPA funds.  
218 Commissioner Andrews seconded the motion.  
219 DISCUSSION: Commissioner Ring stated that this organization has brought  
220 forth a detailed budget and that she looks forward to seeing that red door in  
221 Biddeford ME.  
222 Commissioner Clark asked that My Place also submit an audit.  
223 Commissioner Sicard added that the Commissioners also have a seat on the  
224 Board. Commissioner Sicard suggested that we work with our attorney on  
225 how to disburse funds.  
226 Commissioner Dutremble added that we also consult with our counsel to  
227 make sure that this (project) qualifies for the ARPA money.  
228 County Manager Zinser replied that he does think this project will qualify but  
229 one of the things that is technically missing is how it meets certain provisions  
230 of the ARP money. This approval is subject to a legal review and any and all  
231 contract provisions.  
232 Commissioner Clark amended his motion to approve up to \$1.5 million be  
233 approved for My Place Teen Center with the understanding that our people  
234 will work with their people. Commissioner Andrews seconded the motion.  
235 Vote 5-0.  
236  
237 Commissioner Sicard stated that the Commissioners received today a request  
238 from the Center for Grieving Children that is way pass the deadline. He  
239 motioned that the Commissioners direct the County Manager to send them a  
240 letter to let them know they have missed the deadline. Commissioner Ring  
241 seconded the motion.  
242 DISCUSSION- Commissioner Clark stated that while he understands that they  
243 are late with their request, he wouldn't refuse it on that basis. He continued  
244 that his attitude was that he considered our deadline as a soft one.  
245 Commissioner Sicard replied that he strongly disagreed and that we will have  
246 a dozen more agencies come forward. We are months into this, continued  
247 Commissioner Sicard. We advertised our public hearings.  
248 Vote 3-2 with Commissioner Clark and Commissioner Dutremble opposed.  
249

250 County Manager Zinser asked the Commissioners if they want him to do  
251 anything on transit? Commissioner Dutremble replied that they are coming  
252 back with more information.  
253 County Manager Zinser asked about Fairtide to which Commissioner  
254 Dutremble replied that she is supposed to get back to the Board with more  
255 information.  
256 The County Manager asked the Commissioners how they would like to  
257 proceed with the next round of meetings? He asked if they'd like to hear from  
258 someone about the dredge, York Hospital Recovery and Choose to Be  
259 Healthy. Commissioner Clark responded that he is more interested for the  
260 proposal for behavioral health but that he wanted to hear about both.  
261 Commissioner Sicard added that the host communities are talking about the  
262 dredging. Mayor Doyle is on the ZOOM call.  
263 Commissioner Clark asked that they each have 25 minutes (to present their  
264 requests). Commissioner Sicard stated that he feels it is appropriate to talk to  
265 legal counsel whether it (the dredge) falls under the ARP in categories such as  
266 infrastructure, tourism and/or working waterfront.  
267 The County Manager replied that he hasn't given that heavy consideration.  
268 It's not an actual proposal so he stated that he thinks we need to ask them for a  
269 proposal and let the Board have a conversation about it. Commissioner  
270 Dutremble added that the Board needs not only a proposal but a photo of what  
271 they want to buy.  
272 Commissioner Ring commented that it would be nice to stick to a category.  
273 There are four more affordable housing proposals. County Manager Zinser  
274 responded that it comes down to the priority of the Board. The Board might  
275 want to have some type of discussion about priorities as he thinks there are  
276 many requests that can quickly dispensed of. He added that they are worthy  
277 projects but we can probably go through and eliminate quite a few of them.  
278 Commissioner Dutremble stated that there are some (requests for funding) that  
279 aren't going to meet the Board's approval and they should get a letter.  
280 Commissioner Sicard suggested the Commissioners continue to meet on the  
281 2<sup>nd</sup> and 4<sup>th</sup> Wednesdays to focus on ARP items as he would like to have a good  
282 handle on the projects by the end of the year. Commissioner Sicard reminded  
283 all that they also need to go back over the County's requests.  
284 Commissioner Clark suggested that they meet next Wednesday at 3:00 and  
285 review the remaining request and see who else we want to invite.  
286 Commissioner Clark motioned to meet next Wednesday at 3:00 for another  
287 workshop to work our way through the (ARP requests) book. Commissioner  
288 Sicard seconded the motion. Vote 5-0.

- 289  
290 h. Discussion and possible approval of remote meeting policy-  
291 County Manager explained that this draft policy was created at the request of  
292 the Commissioners.  
293 Commissioner Ring motioned to approve the remote meeting policy as  
294 presented (attached as record of these minutes). Commissioner Andrews  
295 seconded the motion.  
296 Discussion: Commissioner Clark stated that he will be voting against this.  
297 He continued that the Commissioners met in person during COVID and that is  
298 to their credit. Commissioner Clark continued that he has participated in  
299 ZOOM meetings and he doesn't find it useful. It is second rate. If you can't  
300 make the meeting, that's that. Commissioner Clark went on to say that he

301 doesn't think participation from home works. It messes up the flow of the  
302 meeting. Missing a meeting happens.  
303 Commissioner Ring responded that she thinks that in today's world, ZOOM  
304 isn't always perfect, but there are many decisions that are made remotely.  
305 Situations happen, continued Commissioner Ring. This policy isn't for us to  
306 stay home. It's for emergencies. We should have that ability. It happens  
307 more frequently in today's world. I see nothing wrong with this policy, stated  
308 Commissioner Ring. Vote 2-3 (Commissioners Dutremble, Sicard and Clark  
309 opposed). MOTION FAILS  
310

- 311 i. Discussion of Declaration of limited State of Emergency for hiring reservists-  
312 County Manager Zinser explained that Commissioner Dutremble signed(the  
313 limited State of Emergency) last week. We are staffing the vaccine center and  
314 now purchasing a testing machine. The recommendation, stated the County  
315 Manager, is that the Board reimplements a state of emergency in York County.  
316 EMA Director Art Cleaves addressed the Board and recommended the  
317 reinstatement of the State of Emergency. Tuesday, Thursday and Saturdays  
318 the vaccination center is open, explained Director Cleaves. Tomorrow we  
319 have some of our people going to Thornton Academy to give 70 shots.  
320 County Manager Zinser explained that the management and oversight of 60  
321 people is a huge undertaking.  
322 Commissioner Clark commented that he would like to commend EMA  
323 Director Cleaves and the folks that work under him for the services they  
324 provide.  
325 Commissioner Clark motioned to declare a civil emergency for the next 90  
326 days and reconsider when we meet in late December and early January to see  
327 where we are. Commissioner Sicard seconded the motion.  
328 DISCUSSION- Commissioner Ring asked does that apply just for EMA or all  
329 departments in county government? County Manager Zinser replied, just  
330 EMA.  
331 Vote 5-0.  
332

333 **7 OLD BUSINESS**

334 None  
335

336 **\*\*\*Heard after Item 9\*\*\***

337 **8 TO CONDUCT AN EXECUTIVE SESSION ON PERSONNEL**  
338 **ISSUES PURSUANT TO 1 M.R.S.A. §405 (6) (A), ACQUISITION OF**  
339 **REAL PROPERTY OR ECONOMIC DEVELOPMENT PURSUANT**  
340 **TO 1 M.R.S.A. § 405 (6) (C), LABOR NEGOTIATIONS PURSUANT**  
341 **TO 1 M.R.S.A. § 405 (6) (D) AND CONSULTATION WITH LEGAL**  
342 **COUNSEL PURSUANT TO 1 M.R.S.A. § 405 (6) (E), REVIEW OF**  
343 **CONFIDENTIAL RECORDS PURSUANT TO 1 M.R.S.A. § 405 (6) (F)**

344 Commissioner Clark motioned to enter into executive session pursuant to 1  
345 M.R.S.A. §405 (6) (A). Commissioner Sicard seconded the motion. Vote 5-0.  
346 Commissioner Clark motioned to come out of executive session. Commissioner  
347 Sicard seconded the motion. Vote 5-0.  
348 No action taken.  
349  
350

351  
352  
353  
354  
355  
356  
357  
358  
359  
360  
361  
362  
363  
364  
365  
366  
367  
368  
369  
370  
371  
372  
373  
374  
375  
376  
377  
378  
379  
380  
381  
382  
383  
384  
385  
386  
387  
388  
389  
390  
391  
392

**9 PUBLIC COMMENT(S) ON ANY ITEM(S)**

County Manager Zinser clarified that the State of Emergency is for EMA purposes and has nothing to do with the Sheriff's Office and operations of the jail.

**10 ADJOURN**

Commissioner Sicard motioned to adjourn. Commissioner Ring seconded the motion. Vote 5-0. Meeting adjourned at 7:00 p.m.

DRAFT

1 **COMMISSIONERS WORKSHOP ON AMERICAN RESCUE PLAN FUNDING**

2  
3 **October 13, 2021**

4  
5  
6 *YORK,ss*

7  
8 At a Workshop of the County Commissioners of the County of York, begun and  
9 holden at the York County Government Building in Alfred, within and for the County of York,  
10 being held on Wednesday, October 13, 2021 A. D. at 3:00 P. M.

11  
12  
13 **COMMISSIONERS PRESENT:**

- 14  
15 Richard R. Dutremble  
16 Richard Clark  
17 Robert Andrews  
18 Allen Sicard  
19 Donna Ring  
20  
21

22  
23 County Manager Gregory Zinser was present at the meeting.  
24

25  
26 **MASKS ARE REQUIRED TO BE WORN BY ALL WHO ATTEND THE MEETING**



27  
28 **YOU ARE INVITED TO RISE AND SALUTE THE FLAG OF THE UNITED STATES**

29  
30  
31 **10-13-21 ITEM**

32  
33  
34 **1 TO REVIEW AND DISCUSS REMAINING ARP FUNDING REQUESTS**

35  
36 County Manager Zinser began the review of the requests with **South Berwick and North Berwick**  
37 **Water District** – Commissioner Dutremble stated that while it is a worthwhile project, how do the  
38 Commissioners distinguish what city/town gets funding? Usually, these types of projects are in  
39 their own budgets. Commissioner Sicard stated that there is also State and Federal sewer and water  
40 money available. He directed that he would wish them well and move on.

41 County Manager Zinser asked for clarification from the Commissioners on the water projects,  
42 asking if they are saying no to all including the City of Saco. Commissioner Ring added Waterboro  
43 also asked for money for their water district. County Manager Zinser replied, not in writing.  
44 Commissioner Sicard directed the County Manager to send them a letter thanking them for coming  
45 to the public hearing regarding their request.  
46

47 **Affordable Housing-** County Manager Zinser explained that engineering and code review on our  
48 jail property has begun. At some point, we will have to get into a land leasing agreement with  
49 Sanford Housing Authority.

50 **Fair Tide-** County Manager Zinser reminded the Commissioners that they heard from Emily  
51 Flinkstrom from Fairtide last week and are waiting for further information.  
52 Commissioner Sicard recommended sending those who wrote letters of support for Fair Tide and  
53 other housing issues that we are working with Fairtide.

54 **Volunteers Of America-**Commissioner Ring stated that they do our pre-trial. Commissioner  
55 Sicard add that they do housing in Saco. Commissioner Ring replied that they are very active in  
56 central and southern Maine and that she wouldn't mind hearing a little more from them. County  
57 Manager Zinser reminded all that their proposal sounds similar to the TIPS program mentioned at  
58 one of the public hearings. The County Manager added that the mental health committee set up  
59 will deal with these items. Commissioner Sicard added that they do get a lot of Federal funds.  
60 He proposed sending them a letter to thank them for their efforts and to tell them we are working on  
61 this and funding a teen center in Biddeford.

62 **James Nimon-Sanford Springvale growth council director-** County Manager Zinser stated that  
63 his proposal was for broadband and housing. The County Manager commented that in a recent  
64 survey in York County, he believed that broadband didn't make it very high on the list.  
65 Commissioner Sicard advised sending him a letter and inform him we are working on housing with  
66 Sanford Housing and on the topic of broadband, we are waiting for Governor Mills as she has funds  
67 set aside.

68 Commissioner Dutremble stated that MCCA is working with the State on a lot of these projects.

69 Commissioner Clark added that the State is asking for additional funds.

70 The County Manager clarified that this "ask" is for non-entitlement cities and towns that were not  
71 direct recipients (of ARP money) and had to ask for funds.

72 Commissioner Clark commented that no one from Northern York County came to us requesting  
73 any funding for affordable housing.

74 Commissioner Dutremble stated that SMRPDC works with communities to put affordable housing  
75 in all areas of York County.

#### 76 **Social Services**

77 **Youth Connection-** Commissioner Dutremble stated that this center is ½ mile from where the new  
78 teen center will be so this is a duplication of services. They also do good work but are in the same  
79 area. Commissioner Sicard recommended sending them a letter to make them aware of My Place  
80 Teen Center.

81 County Manager Zinser added that they do some summer programming but it looks like this time of  
82 year they are only open one day a week. Commissioner Dutremble added that they also renovated  
83 their building and run a bicycle shop.

84 **St. Louis Alumni Association-**Commissioner Dutremble recused himself. Commissioner Ring  
85 stated that this is a great organization but there are lots of other schools that give out scholarships.  
86 Commissioner Dutremble stated that they do BEANO and other events to raise money. They  
87 received about \$1 million from the sale of their building.

88 Commissioner Sicard directed that a letter be sent to them thanking them for their work in their  
89 community and wish them well in the future.

90 **Choose to Be Healthy Coalition-**County Manager Zinser reminded the Board that they have  
91 requested them to be here next week. He explained that they are looking roughly for \$375,000 over  
92 a 3 year period. We see the effects of drugs and alcohol because of what we do.

93 **York Hospital Recovery Center** is requesting funding for detox and recovery, explained the  
94 County Manager. They will also be here next week per your request. He continued that it looks  
95 like they are requesting around \$680,000 over a 3- year period.

96 **Knights of Columbus-** County Manager Zinser explained that they are asking for \$15,000 to be  
97 able to continue with their programming.

98 Commissioner Dutremble stated that he had already told them no. Commissioner Sicard directed  
99 they also be sent a letter.

100 **Janet Drew** has sent in letters regarding diversion programs, explained County Manager Zinser.  
101 Commissioner Andrews suggested including her on some of those committees so she feels we are at  
102 least being responsive to her. The County Manager replied that it is up to the Commissioners but  
103 that they are not really here to discuss this tonight.

104 Commissioner Ring asked when do we anticipate committees starting to meet?  
105 County Manager Zinser responded that he did send letters to the organizations. Part of the process  
106 is to create partnerships. Letters were also sent to police and fire chief's associations, he continued.  
107 He estimated the committees to start to meet maybe towards the middle or end of November.

108 **VERA Institute of Justice**- County Manager Zinser informed all that they are requesting \$4.5  
109 million. Commissioner Clark commented that the State has to come to grips with juvenile  
110 incarcerations. He added that this is really not our stuff and that he doesn't see this as something  
111 we can do. While a worthy project it is not a direct county concern.

112 **York County Shelter Programs, Inc.**-County Manager Zinser stated that they are proposing a  
113 York County Safety net similar to Fair Tide's proposal for a community hub. Commissioner Sicard  
114 asked if they are plugged in to the transportation? County Manager Zinser responded that there are  
115 a few different things going on with bussing and a route system. "On demand" is more specific to  
116 social service agencies getting their clients from point A to B. He continued that he doesn't know if  
117 busing would work. The County Manager stated that the County did give the shelter 3 or 4 cars at  
118 the beginning of the summer. Commissioner Sicard asked if they need vans? If so, they'd have to  
119 hire drivers. Commissioner Sicard stated to make sure all non-profits are plugged in to the  
120 transportation as this moves on. He added that people do need to get together and work together.  
121 Commissioner Clark stated that he understands the concern about overlap, but, keep in mind that a  
122 social service center in Kittery will not help those in rural areas in York County. Some of their  
123 problems are transportation. We take for granted that we have a car. Transportation is a real  
124 problem for some folks who need help. You have to put this stuff where people can get to it,  
125 continued Commissioner Clark. So, you may have to do it more than once. Commissioner Ring  
126 stated that perhaps the Commissioners should ask them to come in to give us more detail.  
127 Commissioner Sicard stated that maybe Megan's input could help the transportation folks. This  
128 could be a game changer if done right. Transportation is a key piece of what we are trying to do in  
129 York County, stated Commissioner Sicard.

130 Commissioner Ring suggested that the County Manager follow up with her. Commissioner Sicard  
131 agreed that they need to get an update and make her aware that we have had one brief transportation  
132 meeting.

133 **TRANSPORTATION**- Laura Vittorioso sent in a letter with suggestions including transportation  
134 for those who are vision impaired, explained the County Manager. Commissioner Ring directed  
135 the County Manager to respond to her that we are looking into transportation issues.

136 **SMRPD**- County Manager Zinser explained that their letter offers us assistance.

137 **York County Community Action**-Barbara Crieder's letter, explained the County Manager is  
138 letting us know about broadband and her other letter is informational and offering us assistance.

139 **STSolutions (Al Shutz)** The County Manager explained that we heard from him last week.  
140 Commissioner Clark stated that most of what the Commissioners talk about with transportation is  
141 going to rely on York County Community Action. The county is not going to run a transportation  
142 company, continued Commissioner Clark. He commented that he thinks the Commissioners should  
143 urge these organizations to sit down together and talk about what they think they can do and come  
144 to us with a proposal. He added that he is in favor of supporting transportation systems in York  
145 County but that he doesn't think the county can plan that. Someone has to bring it to us. They are  
146 in the business, we are not. Give them a deadline to get back to us with a proposal. County  
147 Manager Zinser replied that he can send them all a letter. Commissioner Clark stated that we can  
148 offer them space to meet in.



149 Commissioner Ring stated that they were pretty clear that the County wasn't going into the  
150 business. Commissioner Sicard stated that they were coming from very different places. It is a lot  
151 different talking about social service agencies. He suggested having Megan (Gene Gendron from  
152 the York County Shelter Programs, Inc.) into the group as a representative of the non-profits.  
153 Commissioner Sicard added that if we have to create an entity to start this, he is okay but not  
154 being directly involved. They need to bring a collective proposal to the County. Commissioner  
155 Dutremble stated that every entity should not say that they should be singled out. It needs to be a  
156 unified proposal. Commissioner Dutremble added that he knows from working in the city of  
157 Biddeford that this has been a problem for a long time.

158 **EMS-** County Manager Zinser explained that a lot of this will come up in the training center  
159 conversations and behavioral health. Chief Hooper understands where we are heading. The  
160 County Manager will send letters to EMS supporters listed to tell them what we are up to.  
161 Commissioner Sicard stated there will need to be discussions with Chief Hooper regarding the  
162 training facility as to operationally, how it will move forward. They need a plan to operate it.  
163 County Manager Zinser said that will be part of the committee's task that to develop plans for its  
164 operation. Commissioner Sicard replied that needs to be flushed out before it comes back.  
165 Otherwise, he stated, that he is not comfortable supporting any of it.

166 **Dredge-** The County Manager reminded the Commissioners that they will be hearing from those  
167 folks next week.

168 **Town of Kennebunk-** The County Manager explained that they sent a detailed list of projects and  
169 that he will send them a thank you.

170 **Biddeford Food Pantry-** County Manager Zinser stated that they had requested \$26,629 for solar  
171 panels and an additional \$20,000 for operational expenses.

172 Commissioner Ring asked if most towns have their own food pantries? County Manager Zinser  
173 replied that a lot of towns do. Commissioner Ring replied that this is relatively short money so she  
174 would keep this in mind. Commissioner Ring suggested maybe give money to various food  
175 pantries throughout the county. She added that there is a lot of short money(requests) in here.  
176 Affordable housing, detox, social services and transportation and the dredge are the items we are  
177 mainly focused on. Commissioner Clark replied that they are big ticket items.

178 County Manager Zinser stated that if the Board wants to talk about the food pantries, maybe  
179 looking at the towns in your districts (would be helpful). He reminded the Commissioners that  
180 some towns are stating they don't know what they are going to do with their money. This  
181 gentleman was not aware that towns and cities are getting their own money.

182 County Manager Zinser reminded the Commissioners that they talked about in the very beginning,  
183 we are saying no right now. As the process goes on, maybe some of this stuff will go down (in  
184 cost) and additional funds may become available. Maybe another opportunity to review some of  
185 these past projects or another project may present themselves, stated the County Manager.

186  
187

188 **2 ADJOURN**

189 Workshop adjourned at 4:17 p.m.



# Intercept

## Full Body Scanner

### *Quick Start Guide*

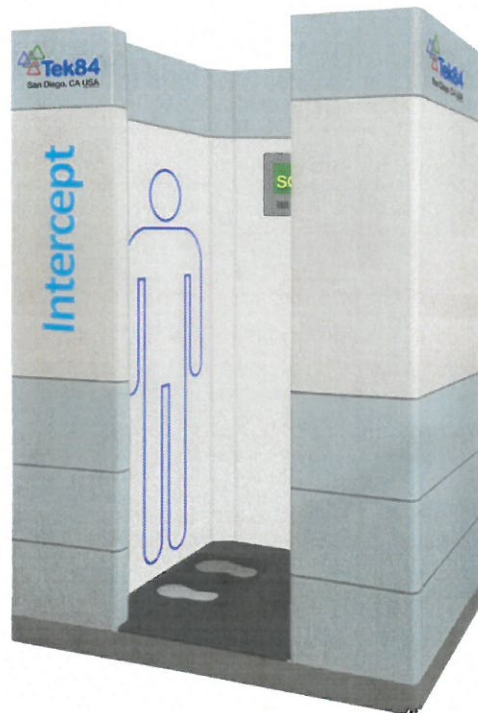

# Table of Contents

<b>1</b>	<b>POWERING UP</b> .....	<b>1</b>
1.1	KEY SWITCH.....	1
1.2	LOGGING IN.....	1
1.3	PREPARING THE SCANNER .....	2
<b>2</b>	<b>HOW TO SCAN SUBJECTS</b> .....	<b>4</b>
2.1	ENTERING SUBJECT INFORMATION .....	4
2.1.1	<i>Add New Subject from Home Screen</i> .....	4
2.1.2	<i>Add New Subject from Find Subject Screen</i> .....	6
2.1.3	<i>No ID Scan</i> .....	6
2.1.4	<i>Find Existing Subject from Home Screen</i> .....	7
2.1.5	<i>Find Existing Subject from Find Subject Screen</i> .....	8
2.2	SELECTING DOSE LEVEL.....	8
2.3	TAKING SUBJECT'S PHOTO .....	9
2.4	SUBJECT POSITIONING .....	10
2.5	PERFORMING THE SCAN.....	10
2.6	STOP SCAN .....	10
<b>3</b>	<b>REVIEWING THE SCAN</b> .....	<b>11</b>
3.1	SCANID .....	11
3.2	ADJUSTING THE IMAGE .....	11
3.2.1	<i>Brightness / Contrast</i> .....	12
3.2.2	<i>Invert / Reset</i> .....	12
3.2.3	<i>Zoom</i> .....	12
3.3	CHANGE IMAGE VIEWS.....	13
3.4	SCAN RESULTS TOOLBAR.....	13
3.4.1	<i>Subject Information</i> .....	14
3.4.2	<i>Show by ScanID</i> .....	14
3.4.3	<i>Show Last Scan</i> .....	14
3.4.4	<i>Mark As Suspect</i> .....	14
3.4.5	<i>Compare Images</i> .....	14
3.4.6	<i>Rescan Subject</i> .....	17
<b>4</b>	<b>HOW TO VIEW SUBJECTS</b> .....	<b>18</b>
4.1	SUBJECT SEARCH TOOLS .....	18
4.2	VIEW ALL SUBJECT SCANS .....	19
4.3	EDITING SUBJECT NAME .....	19
<b>5</b>	<b>LOGGING OUT</b> .....	<b>20</b>
5.1	LOGGING OUT .....	20
5.2	POWERING OFF.....	20

## List of Figures

FIGURE 1: CONTROL PANEL.....	1
FIGURE 2: LOGIN SCREEN .....	2
FIGURE 3: PREPARE SCANNER BUTTONS .....	3
FIGURE 4: HOME SCREEN .....	3
FIGURE 5: SUBJECT INFORMATION BOX .....	4
FIGURE 6: ENTER SUBJECT ID PROMPT .....	4
FIGURE 7: NO SUBJECT FOUND MESSAGE.....	5
FIGURE 8: ENTER NEW SUBJECT SCREEN .....	5
FIGURE 9: ADD SUBJECT (FIND SUBJECT SCREEN).....	6
FIGURE 10: SEARCH BY LAST NAME (HOME SCREEN).....	7
FIGURE 11: SUBJECT RECALLED (HOME SCREEN) .....	8
FIGURE 12: FIND SUBJECT SEARCH .....	8
FIGURE 13: SCAN DOSE LEVELS .....	9
FIGURE 14: TAKE SUBJECT PHOTO .....	9
FIGURE 15: SUBJECT PHOTO CAPTURED .....	9
FIGURE 16: SCAN BUTTONS.....	10
FIGURE 17: SCAN RESULTS SCREEN .....	11
FIGURE 18: IMAGE DISPLAY CONTROLS .....	12
FIGURE 19: HIRES, 3D ENHANCED AND DETAIL IMAGE VIEWS (L TO R) .....	13
FIGURE 20: SCAN RESULTS TOOLBAR .....	13
FIGURE 21: COMPARISON OPTION MENU .....	15
FIGURE 22: COMPARE SCAN TO CURRENT SUBJECT IMAGES .....	16
FIGURE 23: COMPARE IMAGES SCREEN .....	16
FIGURE 24: RESCAN SUBJECT RECALLED .....	17
FIGURE 25: FIND SUBJECT SCREEN .....	18
FIGURE 26: SUBJECT DATA BOX.....	19
FIGURE 27: EDIT SUBJECT NAME PROMPT.....	19

## 1 POWERING UP

### 1.1 Key Switch

To power up:

1. Insert the key in the Control Panel (Figure 1, Item 5).
2. Turn the key 90° clockwise. When the key is in the horizontal position the system is on.
3. The blue power light indicates power is on (Figure 1, Item 4).

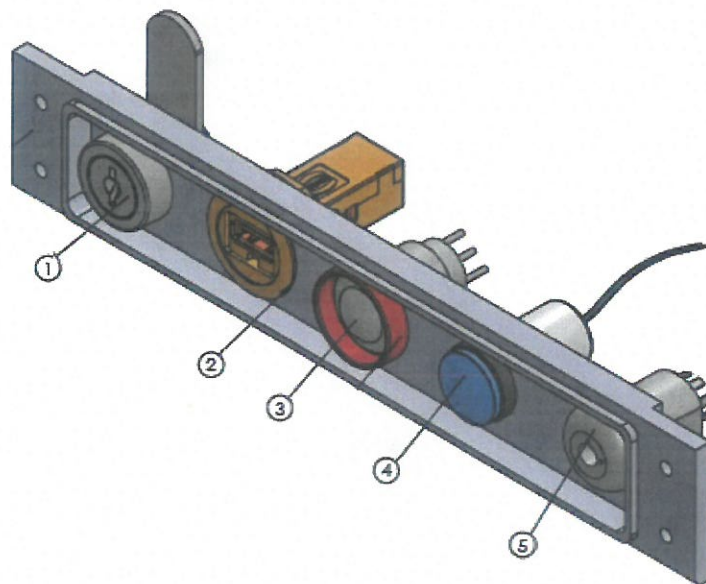

**Figure 1: Control Panel**

### 1.2 Logging In

The Login Screen displays two (2) minutes after powering up (Figure 2). The touchscreen technology can recognize input from a gloved finger.

A valid User ID and Password or a PIN is required to log in. There are two (2) ways to log in to the system:

- User ID and Password
- PIN

Choose a method of login and proceed. After a successful login, the Home Screen displays (Figure 4).

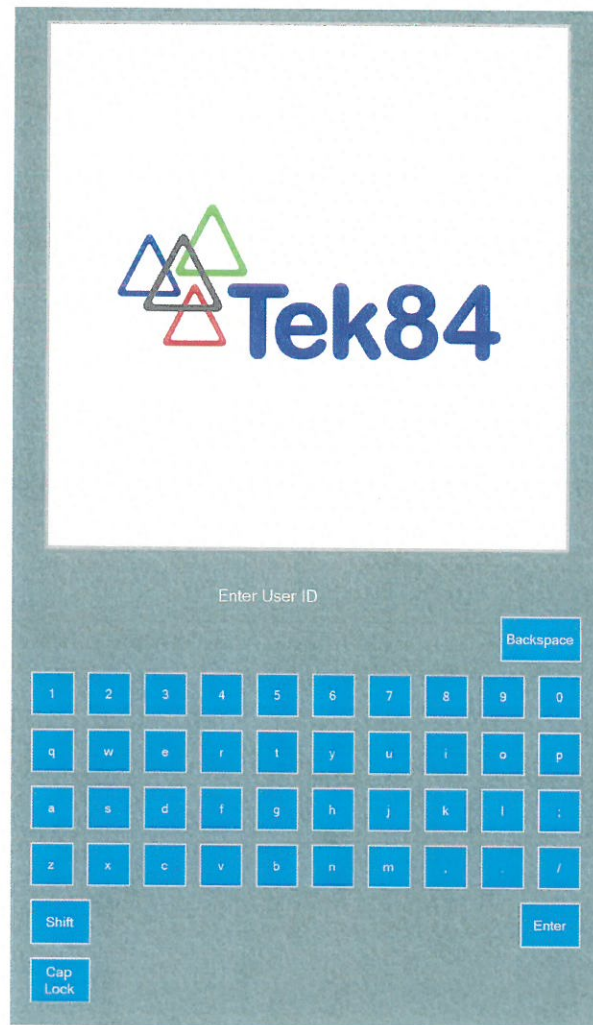

**Figure 2: Login Screen**

### 1.3 Preparing the Scanner

If Intercept was restarted or turned on from off, **Prepare Scanner** buttons appear instead of the Home Screen after logging in. The final step of the boot-up process is **Prepare Scanner** (Figure 5).

Only one (1) button lights up at a time. Press the left sided **Prepare Scanner** button. Then, the right sided **Prepare Scanner** button lights up. Press the buttons from left to right.



**Figure 3: Prepare Scanner Buttons**

When complete the following happens and Intercept is now ready to scan:

1. The system loads the Home Screen (Figure 4)
2. **Prepare Scanner** buttons change to **Scan** buttons.

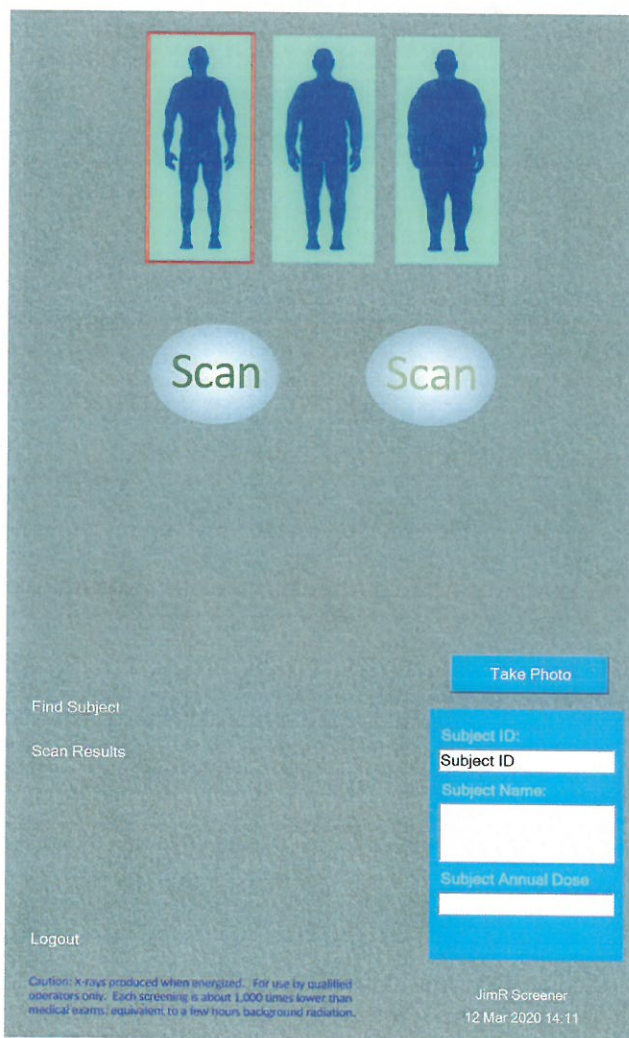
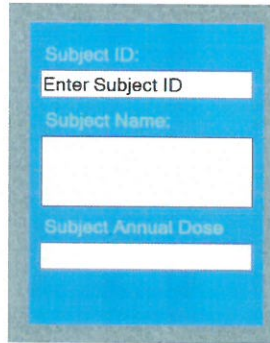

**Figure 4: Home Screen**

## 2 HOW TO SCAN SUBJECTS

### 2.1 Entering Subject Information

Enter the subject's information on the Home Screen (Figure 5).



A screenshot of a blue-themed form titled "Subject Information Box". It contains three input fields: "Subject ID:" with a text box containing "Enter Subject ID", "Subject Name:" with a larger text box, and "Subject Annual Dose:" with a text box.

**Figure 5: Subject Information Box**

If the subject is new, add the subject's information to the system.

#### 2.1.1 Add New Subject from Home Screen

To add a new subject from the Home Screen, select the **Subject ID** box (Figure 5). This brings up the on-screen keyboard (Figure 8). Enter the Subject ID and press **Enter**.

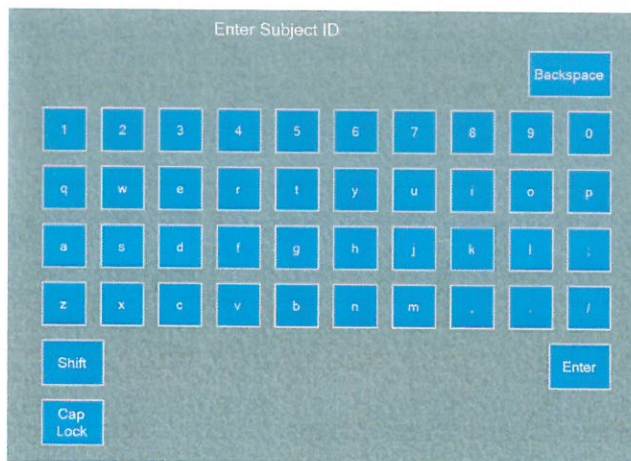

**Figure 6: Enter Subject ID Prompt**

If a new Subject ID is entered, the system displays a pop-up message that the subject was not found and asks if you want to add the subject (Figure 7).



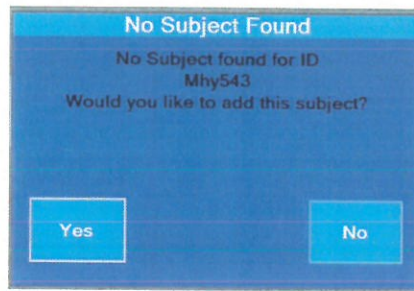

**Figure 7: No Subject Found Message**

Select **Yes** to add the subject. This loads the New Subject Screen that asks for the subject's last, first, and middle name (Figure 8). Enter the required information and press **Save** or **Enter**.

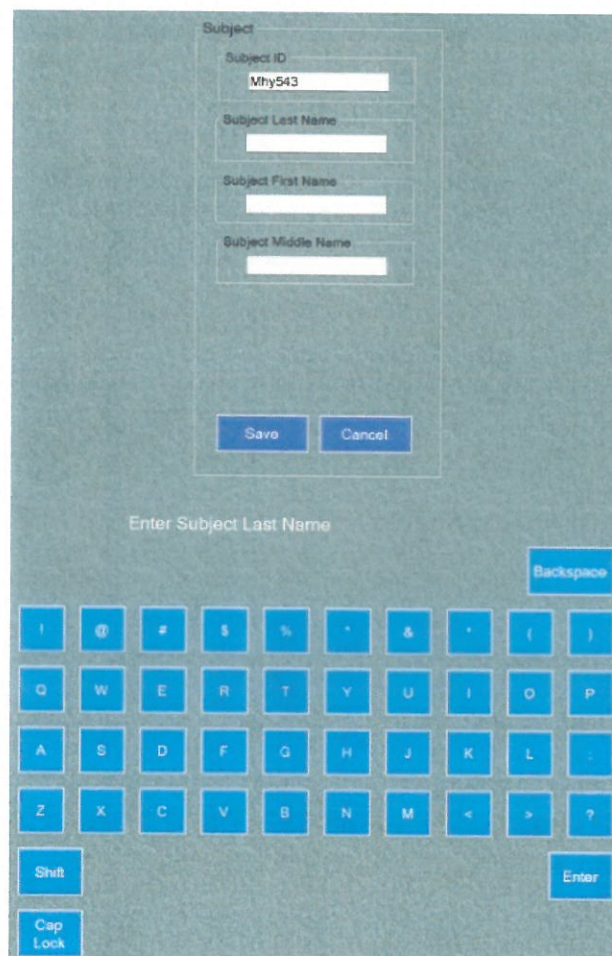
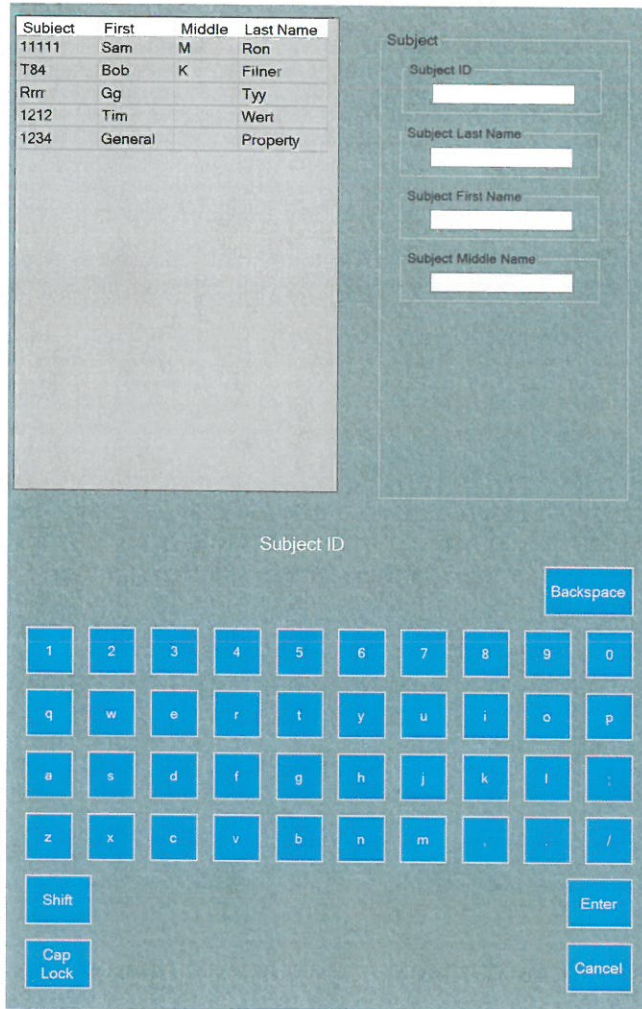

**Figure 8: Enter New Subject Screen**

The new subject is added to the system and the screen returns to the Home Screen (Figure 4).

## 2.1.2 Add New Subject from Find Subject Screen

Alternatively, add a new subject from the Find Subject Screen (Figure 9). Select **Find Subject** from the Home Screen. Then, select **Add Subject**. This opens a New Subject Screen that prompts for the subject's ID, last name, first name, and middle name. Enter the required information as prompted and press **Save** or **Enter** when done.



Subject	First	Middle	Last Name
11111	Sam	M	Ron
T84	Bob	K	Filner
Rrr	Gg		Tyy
1212	Tim		Wert
1234	General		Property

Subject

Subject ID

Subject Last Name

Subject First Name

Subject Middle Name

Subject ID

Backspace

1	2	3	4	5	6	7	8	9	0
q	w	e	r	t	y	u	i	o	p
a	s	d	f	g	h	j	k	l	.
z	x	c	v	b	n	m	.	.	/

Shift      Enter

Cap Lock      Cancel

**Figure 9: Add Subject (Find Subject Screen)**

The new subject appears in the Subject List Box on the left side once added (Figure 9).

## 2.1.3 No ID Scan

If the subject is scanned without being added to the system, the scan is categorized as **No ID**.

If you press **No** to the No Subject Found Message (Figure 7) and do not add the new subject to the system, the screen returns to the Home Screen. A scan performed without information in the Subject Information Box will have no associated identification. Scans without Subject IDs are categorized **No ID** in the database and assigned "-1" for the Subject ID.

## 2.1.4 Find Existing Subject from Home Screen

If the subject is already in the system, find the subject by either the Subject ID or Subject Name. Select the Subject ID or Subject Name field in the Subject Information Box on the Home Screen (Figure 5).

- To search by Subject ID - Enter the Subject ID in the on-screen keyboard. If the Subject ID is already in the system, the matching Subject ID imports into the Subject Information Box.
- To search by Subject Name - Enter at least two (2) letters of the subject's last name in the on-screen keyboard. The list of subjects that match the search parameters displays on the screen (Figure 10).

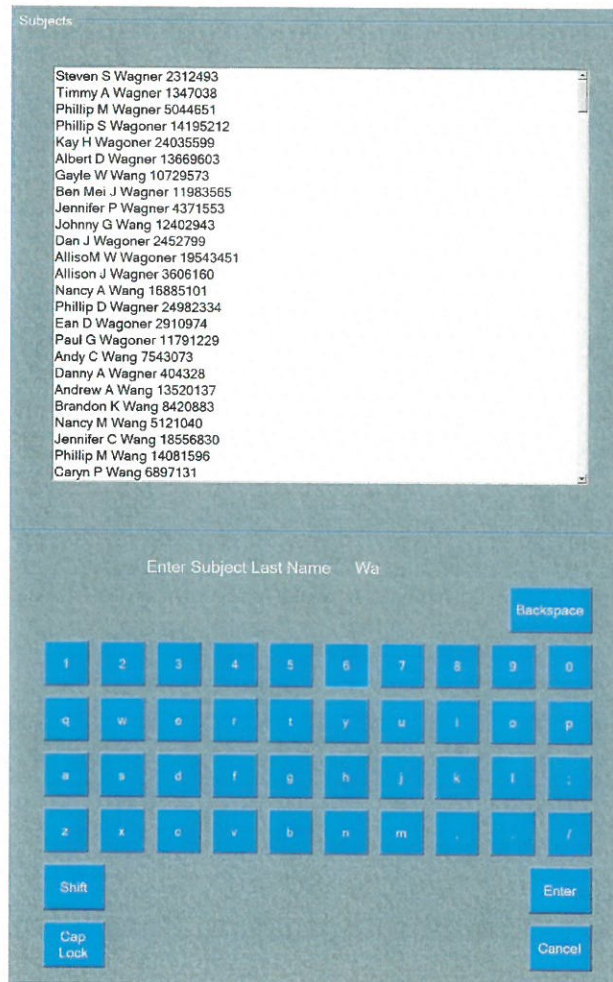

**Figure 10: Search by Last Name (Home Screen)**

Select the subject from the list. The selected subject's information imports into the Subject Information Box on the Home Screen (Figure 11).

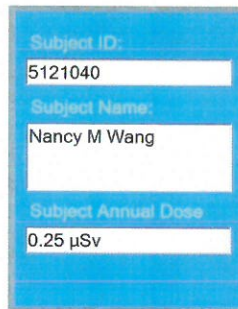

**Figure 11: Subject Recalled (Home Screen)**

### 2.1.5 Find Existing Subject from Find Subject Screen

If the subject is already in the system, alternatively find the subject from the Find Subject Screen. Select **Find Subject** on the Home Screen. See the Search Tools in the Find Subject Screen (Figure 12).

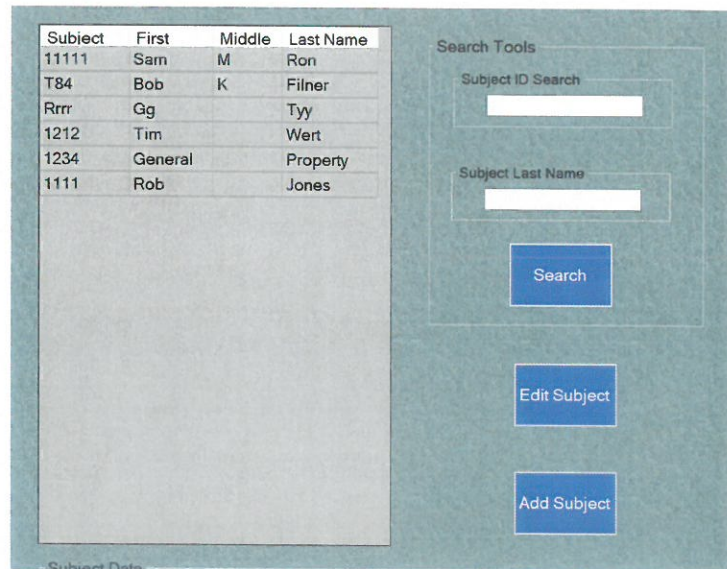

Subject	First	Middle	Last Name
11111	Sam	M	Ron
T84	Bob	K	Filner
Rrrr	Gg		Tyy
1212	Tim		Wert
1234	General		Property
1111	Rob		Jones

Search Tools

Subject ID Search

Subject Last Name

Search

Edit Subject

Add Subject

**Figure 12: Find Subject Search**

Select **Subject ID Search** or **Subject Last Name**. To search by Subject Last Name, enter at least two (2) letters of the last name then press **Enter** or **Search**. Search results that match the search parameters display in the table. Highlight the desired subject and select **Return**. The selected subject's information imports into the Subject Information Box on the Home Screen (Figure 11).

## 2.2 Selecting Dose Level

Select the appropriate Dose Level for the subject before the scan (Figure 13).

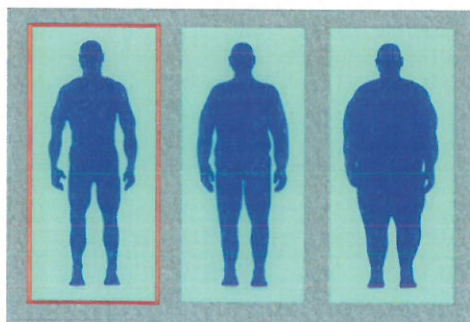

**Figure 13: Scan Dose Levels**

### 2.3 Taking Subject's Photo

Instruct the subject to face the camera located under the Internal Monitor. Press **Take Photo** on the Home Screen (Figure 14).

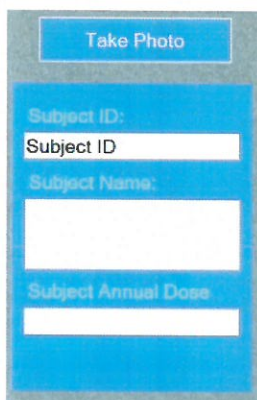

**Figure 14: Take Subject Photo**

The system automatically zooms in on the subject's face, crops the photo, and displays the photo on above the **Take Photo** button (Figure 15).

The subject's photo stays on the Home Screen for two (2) minutes unless you press **Clear Photo** to retake the photo or you perform the scan. Scan the subject within two (2) minutes of the photo capture to attach the photo to the scan. Otherwise, the scan does not include the subject's photo.



**Figure 15: Subject Photo Captured**

## 2.4 Subject Positioning

Instruct the subject to enter the scanner and stand on the footmarks a few inches from the wall with hands to the sides.

## 2.5 Performing the Scan

There are two (2) **Scan** buttons in the middle of the Home Screen (Figure 16).

Only one (1) **Scan** button lights up at a time from left to right. Press the left sided **Scan** button first. Then, the right sided **Scan** button lights up. Press the right sided **Scan** button within five (5) seconds of the left side. Press the two (2) **Scan** buttons from left to right to perform the scan.



Figure 16: Scan Buttons

## 2.6 Stop Scan

If necessary, you can stop the scan in progress at any time during the four (4) second duration. **Stop Scan** button is located on the control panel on the operator kiosk (Figure 1, Item 3).

A Stop Scan message appears on the screen and loads a partially scanned image.

### 3 REVIEWING THE SCAN

After the scan is over, the scan image appears on the Scan Results Screen (Figure 17). Review the image using the controls described below.

#### 3.1 ScanID

At the top of the image is the ScanID. The system generates a unique ScanID for each scan: the first three (3) characters are the Site Code followed by a number that increases sequentially.

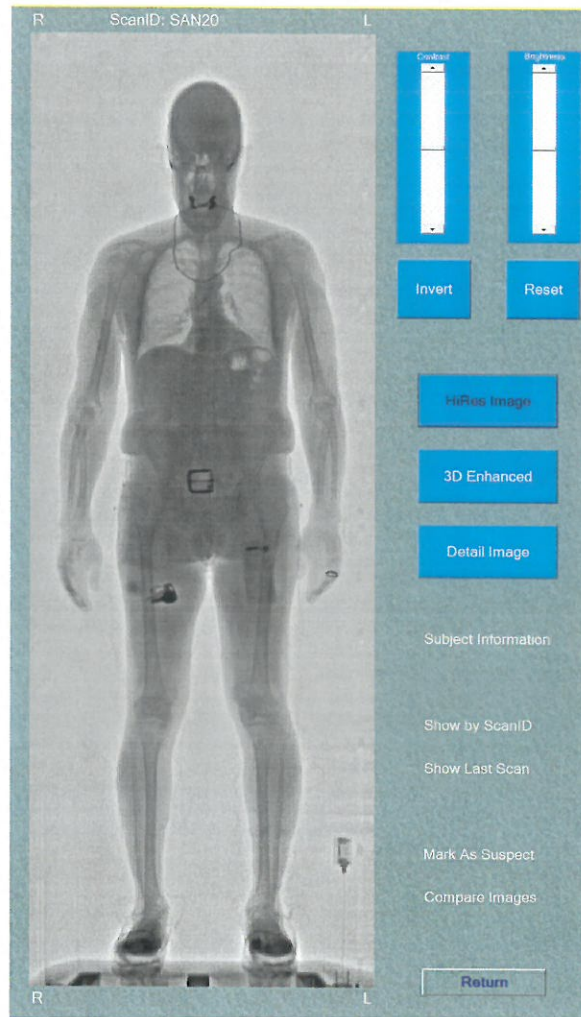

**Figure 17: Scan Results Screen**

#### 3.2 Adjusting the Image

Review the scan image using the Image Display Controls on the Scan Results Screen (Figure 18).

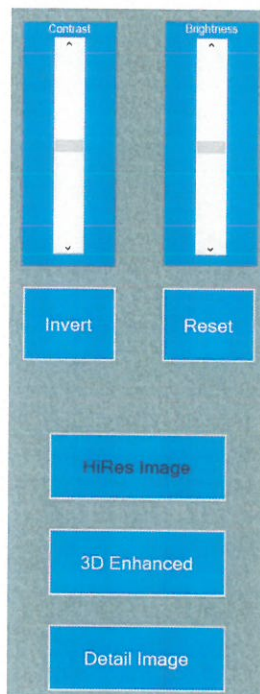

**Figure 18: Image Display Controls**

### 3.2.1 Brightness / Contrast

There are four (4) image display controls available to modify the colorization of pixels.

Use the two (2) scrollbars at the top to adjust the image **Contrast** and **Brightness**: scroll up or press the upward arrow to increase or scroll down or press the downward arrow to decrease.

### 3.2.2 Invert / Reset

Select **Invert** to reverse the colors of the image: white reverses to black, light reverses to dark and vice versa. This is done by inverting all pixel values in the image by changing dark pixels to lighter values and lighter pixels to darker values.

Select **Reset** to return the image brightness and contrast display to the default values. All image adjustments reset automatically when you perform a new scan or log out.

### 3.2.3 Zoom

Tap anywhere on the image to zoom in on the image. The system magnifies the selected area. There is only one (1) zoom level. Touch the screen again to zoom out and return to the original view.



### 3.3 Change Image Views

There are three (3) different ways to view the image: **HiRes**, **3D Enhanced**, and **Detail Image** (Figure 19).

The default image view is **HiRes** (Figure 17). Select **3D Enhanced** or **Detail Image** to review the image in different views (Figure 19).

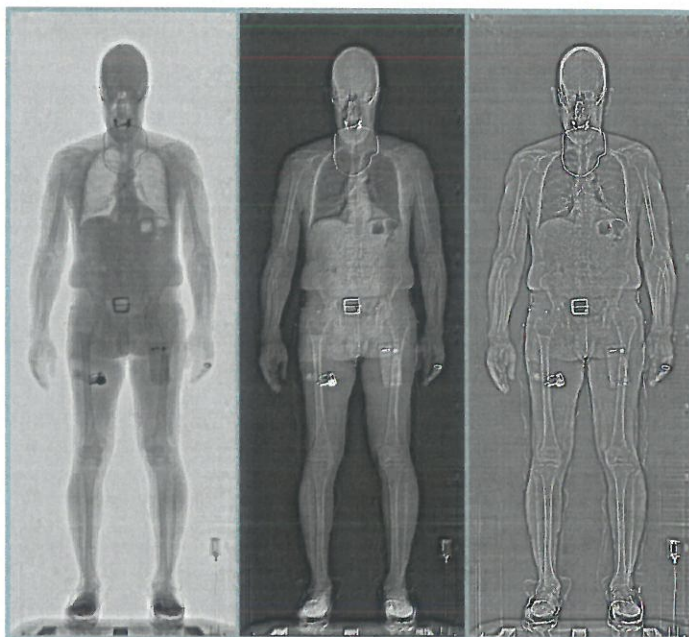

**Figure 19: HiRes, 3D Enhanced and Detail Image Views (L to R)**

### 3.4 Scan Results Toolbar

There are additional buttons on the Scan Results Screen in the Scan Results Toolbar (Figure 20).

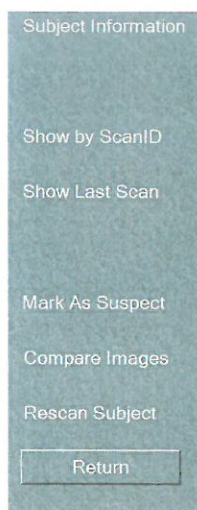

**Figure 20: Scan Results Toolbar**

### 3.4.1 Subject Information

Select **Subject Information** to view the following information about the scanned subject: Subject ID, Subject Name, Scan Date and Time, Scan Dose.

### 3.4.2 Show by ScanID

Select **Show by ScanID** to retrieve any scan by ScanID number.

### 3.4.3 Show Last Scan

Select **Show Last Scan** to retrieve the most recent scan image.

### 3.4.4 Mark As Suspect

Select **Mark as Suspect** to flag a scan image as Suspect for any reason.

### 3.4.5 Compare Images

Compare any image to another existing scan image.

Select **Compare Images** to choose the image for comparison. The Comparison Option Menu displays to the right of the current image (Figure 21). Compare the current image to any existing image in any of three (3) ways:

- **Current Subject Images** - Compare to the current subject's previous scan (Figure 22). Select the **Current Subject Images** tab to select from any of the current subject's previous scans.
- **Library Images** - Compare to an image added to the Library (Figure 21). Select the **Library Images** tab to select the desired Library Image for comparison.
- **Search By ScanID** - Compare to any other scan by ScanID. Select **Search by ScanID** to search for a comparison image by ScanID number (Figure 21).

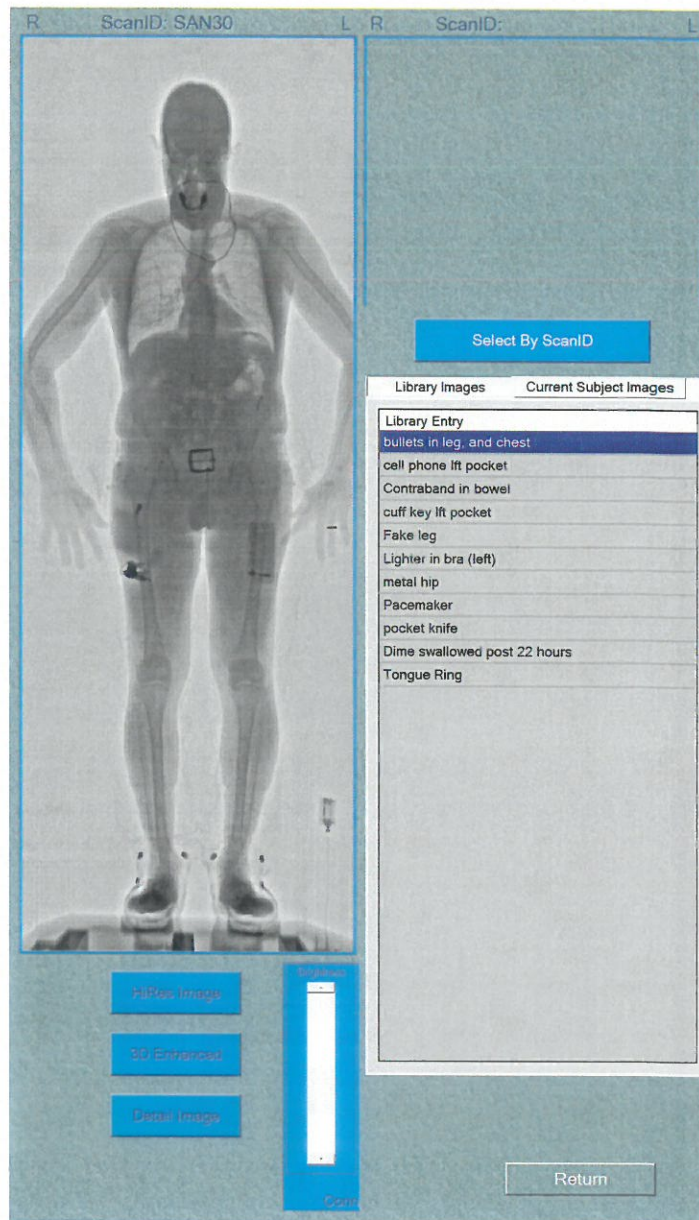

**Figure 21: Comparison Option Menu**

When you select the image for comparison, the two (2) images appear side by side (Figure 23). The same Image Display Controls in Section 3.2, Adjusting the Image, and Section 3.3, Change Image Views, are also available on the Compare Images Screen (Figure 23).

Use the Image Display Controls to compare and review the images. Both images are connected by default indicated by the blue border around both images. The Image Display Controls affect both images when connected.

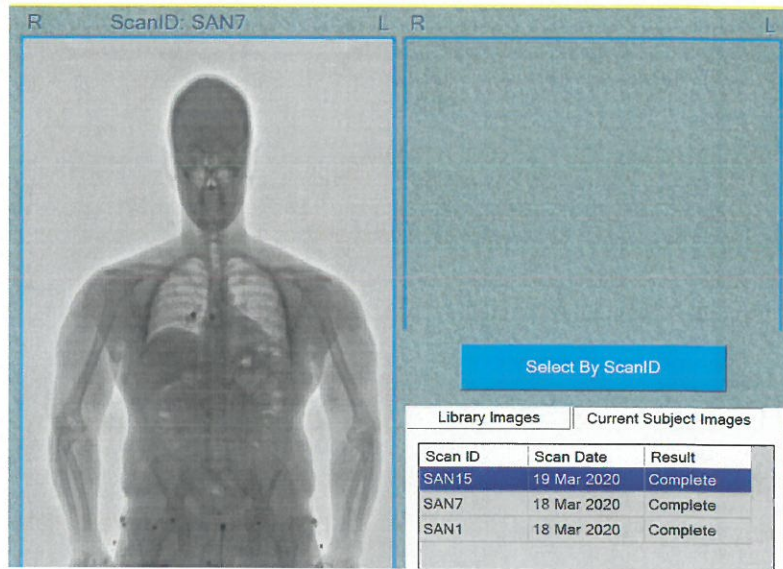

**Figure 22: Compare Scan to Current Subject Images**

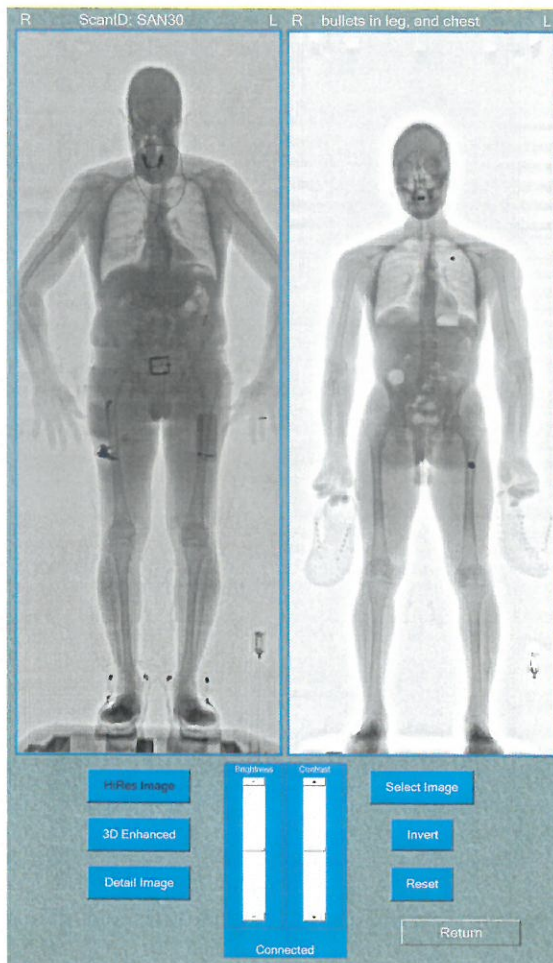

**Figure 23: Compare Images Screen**

To disconnect the images, press **Connected** at the bottom of the screen. This disconnects the images, removes the blue border around the comparison image on the right, and leaves the blue border around the current image on the left. Any adjustments using the Image Display Controls only affects the image highlighted with the blue border. To switch to the comparison image on the right, select the right image.

The blue border highlights the image to indicate it is selected.

To re-connect the two images, press **Connect**.

### 3.4.6 Rescan Subject

If you need to re-scan the same subject for any reason, it can be done quickly with the re-scan feature. This feature is only available for five (5) minutes on the Scan Results Screen immediately after a scan has been performed. The re-scan feature disappears after five (5) minutes. If you exit the Scan Results Screen displaying the recently scanned image, the re-scan feature also disappears.

Select **Rescan Subject** after the initial scan within the five (5) minute window. Selecting this feature returns the screen to the Home Screen and populates the Subject Information Box and the Subject's photo with the same information used for the last performed scan (Figure 27).



**Figure 24: Rescan Subject Recalled**

## 4 HOW TO VIEW SUBJECTS

To view all subjects in the system, select **Find Subject** on the Home Screen.

### 4.1 Subject Search Tools

Use the Subject Search Tools on the Find Subject Screen to find a subject in the system (Figure 25).

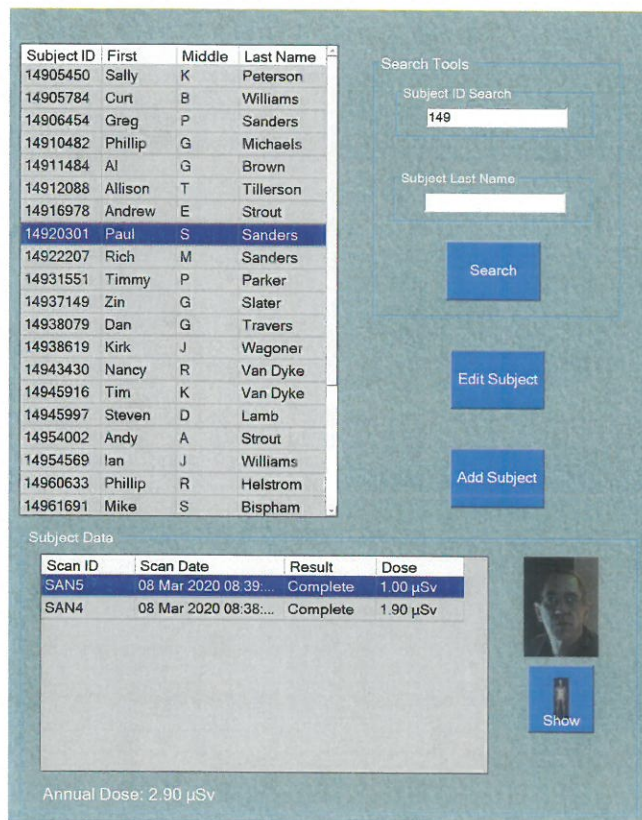

The screenshot shows the 'Find Subject Screen' interface. On the left is a table of subjects with columns for Subject ID, First, Middle, and Last Name. The row for Subject ID 14920301 (Paul S Sanders) is highlighted. On the right is the 'Search Tools' section with two search options: 'Subject ID Search' (with the value '149' entered) and 'Subject Last Name' (with an empty field). Below these are three buttons: 'Search', 'Edit Subject', and 'Add Subject'. At the bottom, there is a 'Subject Data' section with a table of scan results and a 'Show' button next to a subject's photo.

Subject ID	First	Middle	Last Name
14905450	Sally	K	Peterson
14905784	Curt	B	Williams
14906454	Greg	P	Sanders
14910482	Phillip	G	Michaels
14911484	Al	G	Brown
14912088	Allison	T	Tillerson
14916978	Andrew	E	Strout
14920301	Paul	S	Sanders
14922207	Rich	M	Sanders
14931551	Timmy	P	Parker
14937149	Zin	G	Slater
14938079	Dan	G	Travers
14938619	Kirk	J	Wagoner
14943430	Nancy	R	Van Dyke
14945916	Tim	K	Van Dyke
14945997	Steven	D	Lamb
14954002	Andy	A	Strout
14954569	Ian	J	Williams
14960633	Phillip	R	Helstrom
14961691	Mike	S	Bispham

Scan ID	Scan Date	Result	Dose
SAN5	08 Mar 2020 08:39:...	Complete	1.00 µSv
SAN4	08 Mar 2020 08:38:...	Complete	1.90 µSv

Annual Dose: 2.90 µSv

**Figure 25: Find Subject Screen**

The search function here works the same way as the search function described in Section 2.1.4, Finding Existing Subject from Home Screen and Section 2.1.5, Finding Existing Subject from Find Subject Screen. See the sections for reference.

If you press **Search** with empty search parameters, the system loads all existing subjects.

Specify the search parameters with the Search Tools (Figure 25). Select **Subject ID Search** and enter the Subject ID or select **Subject Last Name** and enter at least the first two (2) characters of the subject's last name. Press **Search**. The system displays subjects that meet the search criteria on the Subject List on the left.

## 4.2 View All Subject Scans

Select the desired subject from the Subject List. The Subject Data box below shows all previous scans belonging to that subject. The data includes: Scan ID, Scan Date, Scan Time, Result and the Annual Dose (Figure 26).

To view a scan, select the Scan ID. If a photo was taken with the scan, the subject's photo appears to the right. Press **Show** to view the image on the Scan Results Screen.

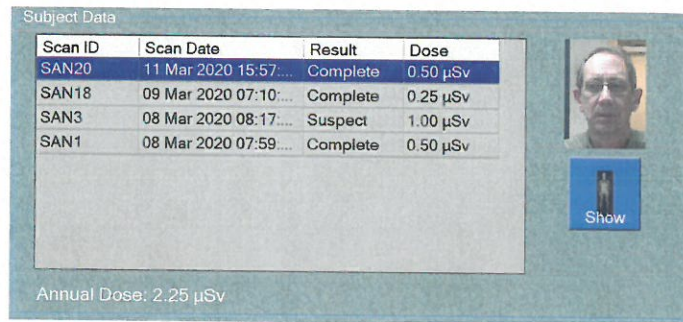

Scan ID	Scan Date	Result	Dose
SAN20	11 Mar 2020 15:57:...	Complete	0.50 µSv
SAN18	09 Mar 2020 07:10:...	Complete	0.25 µSv
SAN3	08 Mar 2020 08:17:...	Suspect	1.00 µSv
SAN1	08 Mar 2020 07:59:...	Complete	0.50 µSv

Annual Dose: 2.25 µSv

Show

Figure 26: Subject Data Box

## 4.3 Editing Subject Name

You can change the subject's name. **Edit Subject** refers to Subject Name. Search for the subject to edit with the Search Tools. Select the subject from the Subject List. Press **Edit Subject**

The on-screen keyboard appears and retrieves the subject's first, last and middle name. To change a field, press **Backspace**, enter the correct name and press **Enter** (Figure 27). To keep the field the same, press **Enter** to proceed to the next name field.

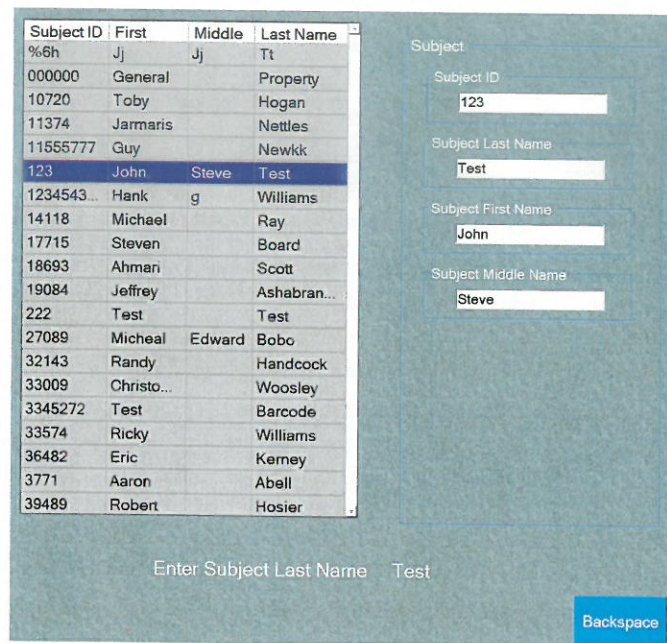

Subject ID	First	Middle	Last Name
%6h	Jj	Jj	Tt
000000	General		Property
10720	Toby		Hogan
11374	Jarmaris		Nettles
11555777	Guy		Newkk
123	John	Steve	Test
1234543...	Hank	g	Williams
14118	Michael		Ray
17715	Steven		Board
18693	Ahmani		Scott
19084	Jeffrey		Ashabran...
222	Test		Test
27089	Micheal	Edward	Bobo
32143	Randy		Handcock
33009	Christo...		Woosley
3345272	Test		Barcode
33574	Ricky		Williams
36482	Eric		Kerney
3771	Aaron		Abell
39489	Robert		Hosier

Subject ID: 123

Subject Last Name: Test

Subject First Name: John

Subject Middle Name: Steve

Enter Subject Last Name Test

Backspace

Figure 27: Edit Subject Name Prompt

## 5 LOGGING OUT

### 5.1 Logging Out

Log out when done scanning.

The **Logout** button is on the bottom left corner of most screens. If the **Logout** button is unavailable, press the **Return** button to return to a previous screen where the **Logout** button is available.

### 5.2 Powering Off

Intercept can be left on for hours or days as needed. To turn the power off, turn the key in the key switch 90° counterclockwise to a vertical orientation.





October 15,2021

Major Nathan Thayer  
 Jail Superintendent, York County Sheriffs Office  
 1 Layman Way, Alfred, Maine 04002  
 Ph:207-459-2203Email: ncthayer@yorkcountymaine.gov

Quote# 2021-10-17

Please see the quotation below for the Tek84 Intercept Whole Body Scanner.

Qty	Part Number	Description	MSRP	Ext. Price
1	SSD-017-1101	Tek84 Intercept Whole Body Security Scanning System  High Strength Aluminum Unibody Frame 160Kv Monoblock Oil Cooled Generator 34" x 72" x 90" (79" top removed) foot print 4 Second Scan Time Variable Scanning Dosage from .25uSv to 2.0uSv  Tethered Ethernet Connected Work Station with 27" Vertically Mounted Touch Screen Monitor PC with Windows Operating System and two(2) 1TB Hard Drives RAID 1,000,000 image storage capacity Transportable on Built In Heavy Duty Caster System With Corner Mounting Feet 16 Million Gray Scale Levels 110V/60hz 1Kva	\$205,000	\$139,000
1	INT- Shipping/Install and Calibration	Freight from San Diego, CA to Alfred ME	INC	INC
1	INT-TRAINING	2. Days Formal On Site Operator Training.	INC	INC
1	INT-WARRANTY-1	<b>Two Year Parts and Labor Warranty</b> on Entire System from time of Installation  Extended Warranty \$7,500.00 after year 2	INC  TBD	INC.  TBD

<b>Special Luminary Site Pricing</b>		<b>Total \$139,000.00</b>
--------------------------------------	--	---------------------------

1 (Optional) PN 13282 FDA Approved Fully Integrated Thermal Scanner/Temperature Scanning \$30,000 \$20,000

Quote Expiration: Jan 15, 2022

By execution of this Agreement by an authorized signature, the Customer agrees to purchase the Products specified subject to the terms and conditions set forth in the Agreement and subject to Tek84 Terms and Conditions available at [www.Tek84.com](http://www.Tek84.com)

DAP: Destination- Alfred ME  
 Terms: Net 30 Days  
 Taxes: ADD as Necessary at or provide exemption certificate

**Accepted By:**  
 Printed Name and Title: \_\_\_\_\_  
 Authorized Signature: \_\_\_\_\_  
 Date: \_\_\_\_\_

**Tek84:**  
 Printed Name and Title: \_\_\_\_\_  
 Authorized Signature: \_\_\_\_\_  
 Date: \_\_\_\_\_

13495 Gregg Street  
 Poway, CA 92064  
 Phone: 858-676-5382  
 www.Tek84.com

**WISCONSIN DEPARTMENT OF JUSTICE**

**DOJ USE ONLY**

Applicant Hereby Applies to the DOJ for Financial Support for the Within-Described Project:

Receipt Date	Award Date	Subgrant Number(s)
		-- 16578

**SUBGRANT #: 16578**

**SHORT TITLE:** Whole Body Thermal Security Scanner

<b>1. Type of Funds for which you are applying.</b>	<input type="checkbox"/> Coronavirus Emergency Supplemental Funds – County Criminal Justice Agencies		
<b>2. Applicant</b>	<b>Name Of Applicant:</b>		<b>County:</b> Marquette
	Marquette County Sheriff's Department		
	<b>Street Address:</b> 67 Park Street		
	<b>Address Line 2:</b>		<b>Address Line 3:</b>
	<b>City:</b> Montello	<b>State:</b> WI	<b>Zip:</b> 53949-9366
<b>3. Recipient Agencies</b>	Marquette County Sheriff's Department		
<b>4. Signatory</b>	<b>Name:</b>		<b>Title:</b> County Board Chair
	Chairman Robert Miller		<b>Agency:</b> Marquette County
	<b>Street Address:</b> 77 West Park Street		
	<b>Address Line 2:</b>		<b>Addr Line 3:</b>
	<b>City:</b> Montello	<b>State:</b> WI	<b>Zip:</b> 53949-9366
	<b>Phone:</b> 608-575-2308	<b>Fax:</b>	<b>Email:</b> rmiller@co.marquette.wi.us
<b>5. Financial Officer</b>	<b>Name:</b>		<b>Title:</b> County Treasurer
	Treasurer Jody A. Myers		<b>Agency:</b> Marquette County Sheriff's Department
	<b>Street Address:</b> 67 Park Street		
	<b>Address Line 2:</b>		<b>Addr Line 3:</b>
	<b>City:</b> Montello	<b>State:</b> WI	<b>Zip:</b> 53949-9366
	<b>Phone:</b> 608-297-3032	<b>Fax:</b>	<b>Email:</b> jmyers@co.marquette.wi.us
<b>6. Project Director</b>	<b>Name:</b>		<b>Title:</b> Sheriff
	Sheriff Joseph R Konrath		<b>Agency:</b> Marquette County Sheriff's Department
	<b>Street Address:</b> 67 Park Street		
	<b>Address Line 2:</b>		<b>Addr Line 3:</b>
	<b>City:</b> Montello	<b>State:</b> WI	<b>Zip:</b> 53949-9366
	<b>Phone:</b> 608-297-2115	<b>Fax:</b>	<b>Email:</b> jkonrath@co.marquette.wi.us
<b>7. Brief Summary of Project</b>  (Do Not Exceed Space Provided)	<b>Short Title</b> (may not exceed 50 characters)		
	Whole Body Thermal Security Scanner  The Marquette County Jail is approved by the Department of Corrections for the detention of adult offenders. There have been operational strains in 2020 and 2021 due to the COVID-19 pandemic. The issues have been assessed and addressed in a highly professional manner. To continue our effort for the safety and security of our correctional officers and inmates from the contagious disease, incorporating a Whole-Body Thermal Security Scanner will greatly improve the initial screening of newly incarcerated inmates for the detection of COVID-19. If the inmate body temperature is higher than normal the inmate can be placed in medical isolation pending the results of a COVID-19 test.		

8. SubGrant Budget

Sources

Categories	Federal	Category Total
Equipment	150,000.00	150,000.00
Supplies & Operating Expenses	0.00	0.00
Consultants/Contractual	0.00	0.00
<b>Source Total</b>	<b>150,000.00</b>	<b>150,000.00</b>

9. Project Start Date: 6/1/2021

Project End Date: 12/1/2021

10. Budget Details:

Master Budgets:

By Recipient Agency	Year 1	Total
Marquette County Sheriff's Department	150,000.00	150,000.00
<b>Total:</b>	150,000.00	150,000.00

Allocation/Recipient Agency: Marquette County Sheriff's Department

Category:	Year 1	Total
Equipment	150,000.00	150,000.00
<b>Total:</b>	150,000.00	150,000.00

11. Budget Details:

Master Budgets:

Line Item Details for Marquette County Sheriff's Department

**YEAR 1**

**EQUIPMENT**

**Justification:** The Coronavirus Emergency Supplemental Funds will be used to purchase the Whole Body Thermal Security Scanner. The cost of the unit is \$169,000.00 and the maximum funding of \$150,000.00 will no doubt assist with the purchase of the equipment. The equipment will be used for temperature taking of newly incarcerated inmates for the detection of COVID-19. This initial stage will protect the correctional officers and the inmates from the contagious virus spreading throughout the jail if the symptoms are detected early on. This will help determine if the inmates will have to go into medical isolation pending the COVID test. At the moment we only depend on the answers to the COVID-19 questionnaire.

COST

<b>Item</b>	Tek84 Intercept Whole Body and Thermal Security System		
<b>Quantity:</b>	1.00	<b>Source:</b> Federal	0.00
<b>Unit Cost:</b>	150,000.00	<b>Source:</b> Federal	150,000.00
	<b>Equipment</b>	<b>Year 1 Total:</b>	<b>150,000.00</b>

**YEAR 1 TOTAL: 150,000.00**

12. Sections:

**A BUDGET NARRATIVE**

The budget should display a clear link to the overall program or project and the proposed budgeted items. The budget narrative should explain how the costs are necessary for the completion of the proposed project.

RESPONSE:

The Coronavirus Emergency Supplemental Funds will make this project possible. The funding used towards the purchase of the Whole Body Thermal Security Scanner will change the process of the initial screening of COVID-19. Temperature taking at the initial stage of booking into the jail of newly incarcerated inmates will no doubt add to the safety and security of correctional staff and inmates. Without the funding we will not be able to purchase the equipment and COVID-19 can easily spread without notice. It is a strong preventive measure. The Whole Body Thermal Security Scanner is the most essential equipment for the early detection of the COVID-19 virus symptom.

BUDGET NARRATIVE - RELATED ATTACHMENTS:

<u>File Name</u>	<u>File Description</u>
------------------	-------------------------

**B PROBLEM OR NEEDS DESCRIPTION**

Describe the problem or issue your county criminal justice system is experiencing during the coronavirus response, explain how this grant funding will solve or diminish identified problems.

RESPONSE:

The Marquette County Sheriff's Office is the only 24/7 law enforcement agency in Marquette County. The Marquette County Jail is the only DOC approved correctional facility in Marquette County. The level of calls for service and subjects getting arrested for criminal violations has increased the risk of the COVID-19 virus spreading and affecting the correctional staff and inmates incarcerated in the jail. The jail population has increased substantially since a year ago when the COVID-19 pandemic first hit. The court opening more and more for in-person hearings has increased the risk of the COVID-19 virus spreading as defendants are pleading and getting sentence to serve time in the Marquette County Jail. For the first time in a year the Marquette County Circuit Court has five (5) jury trials scheduled in May. The criminal justice system is busier and having a Whole Body Security Thermal Scanner in the jail for the initial assessment of COVID-19 will no doubt help with the detection of COVID-19 and stop the possibility of the virus spreading throughout the jail affecting the correctional staff and inmates.

PROBLEM OR NEEDS DESCRIPTION - RELATED ATTACHMENTS:

<u>File Name</u>	<u>File Description</u>
------------------	-------------------------

**C PROJECT NARRATIVE**

Pending

**RESPONSE:**

The Whole Body Security Thermal Scanning System will be used for all incarcerations into the Marquette County Jail. The new policy for the use of the aforementioned equipment will be listed for the temperature taking of all newly arrested subjects entering the Marquette County Jail to detect COVID-19 symptoms. With the early detection of COVID-19 symptoms, arrestees, can be placed in medical isolation for a COVID-19 testing. This procedure will contribute to the safety, security and wellness of correctional staff and inmates. This will also prevent the possible spreading of the disease throughout the jail facility affecting other staff members and inmates. Early detection of COVID-19 symptoms will alert correctional officers and having a procedure in place will protect others from getting affected. This will add another precautionary measure in place for the protection, safety and security of correctional officers and inmates getting affected with the COVID-19 virus.

**PROJECT NARRATIVE - RELATED ATTACHMENTS:**

<u>File Name</u>	<u>File Description</u>
------------------	-------------------------

**14. Approval Checklist:**

- A. Have you, the grant recipient, had any discrimination findings after a due process hearing on the basis of race, color, religion, national origin or sex within the last 5 years? (federal EEOP required response)
  - Yes
  - No
  
- B. If yes, have the discrimination findings been reported to the Office of Civil Rights as required for all recipients of Federal funds? (see <http://www.ojp.usdoj.gov/ocr/>). If no, a copy should be forwarded to: Wisconsin Department of Justice, Attn: EEOP, 17 West Main Street, PO Box 7857, Madison, WI 53707-7857 (federal EEOP required response)
  - Yes
  - No
  - N/A
  
- C. Have you utilized the DOJ Administrative Guide located on the DOJ website? (grants-admin-guide-2018.pdf)
  - Yes

No

D. Would you like someone from DOJ to contact you?

Yes

No

E. Are you a state or local government agency; AND have 50 or more employees; AND applying for \$25,000 or more? If yes, you are required to prepare and implement an Equal Employment Opportunity Plan (EEO) or Certification form (if applicable). A copy of your EEO federal approval letter must be submitted to DOJ. (More information may be found at <http://www.doj.state.wi.us/grants/grantee-civil-rights-information>) (federal EEO required response)

Yes

No

N/A

F. If this application is \$25,000 or more, did your business or organization (including parent organization, all branches, and all affiliates worldwide) receive in the previous fiscal year (1) 80% or more of your annual gross revenues in US federal contracts, subcontracts, loans, grants, subgrants, and/or cooperative agreements?; AND (2) \$25,000,000 or more in annual gross revenues from US federal contracts, subcontracts, loans, grants, subgrants, and/or cooperative agreements? (required by The Federal Funding Accountability and Transparency Act)

Yes

No

N/A

G. If you answered yes to the previous question, does the public have access to information about the compensation of the senior executives in your business or organization (including parent organization, all branches, and all affiliates worldwide) through periodic reports filed under section 13(a) or 15(d) of the Securities Exchange Act of 1934 (15 U.S.C. 78m(a), 78o(d)) or section 6104 of the Internal Revenue Code of 1986? If you answered no to the first part of this question; you must attach to this application the full names and compensation of the top 5 highly compensated individuals of your organization as required by The Federal Funding Accountability and Transparency Act.

Yes

No

N/A

# Intercept Body Scanner

## Recommendations for Pregnant Subjects and Employees

September 14, 2020

By Steven W. Smith, Ph.D.  
President, Tek84 Inc.  
[Steve.Smith@Tek84.com](mailto:Steve.Smith@Tek84.com)

### Summary

The FDA and other safety organizations have addressed the use of body scanners with pregnant subjects and workers. Body scanners operate within the radiation dose allowable for the General Public, less than 250 uSv per year. This is the lowest category defined for radiation protection. This radiation limit was enacted to protect the most vulnerable members of the population, including pregnant women, children and other groups that may have heightened sensitivity to radiation. Accordingly, for purposes of radiation protection, it is unwarranted to treat pregnant subjects or workers differently than other members of the population with regards to body scanner operation.

### Body Scanner Regulation in the United States

There are three key documents for regulating x-ray body scanners in the United States:

#### 1. ANSI/HPS N43.17-2009

##### Radiation Safety for Personnel Security Screening Systems Using X-ray or Gamma Radiation

This is the master regulatory document for body scanner operation in the United States and many other parts of the world. While this is a consensus standard with input from dozens of groups, most of this document was authored by employees of the FDA and represents the agency's official position. In addition, essentially every major radiation protection organization in the United States has endorsed the N43-17 standard. (39 pages)

#### 2. NCRP Commentary Nr 16

##### Screening of Humans for Security Purposes Using Ionizing Radiation Scanning Systems

The National Council on Radiation Protection (NCRP) is the primary organization in the United States that sets radiation limits. In this commentary, NCRP specifically addresses radiation protection in the use of body scanners. (37 pages)

#### 3. National Academies of Science Report to Congress

##### Airport Passenger Screening Using Backscatter X-ray Machines

The National Academies of Science (NAS) is one of the most respected scientific organizations in the world. Congress requested NAS to prepare this report in response to ongoing safety concerns over airport x-ray body scanners. The report was intended to be a comprehensive review of all existing studies and public commentaries. While focused on airport backscatter scanners, much of the material is relevant to the transmission scanners used by correctional institutions. (134 pages)



These organizations are closely aligned in their recommendations for body scanners and frequently cross-reference each other. That is, the provisions of the N43-17 standard should be interpreted as the joint recommendation of FDA, NCRP, and essentially every major radiation protection organization in the United States.

#### **Radiation Dose Limit for the General Public**

The NCRP has long set the annual radiation dose limit for the General Public at 1,000 uSv per year, excluding background radiation and medical examinations. Since a person may come in contact with several sources of radiation during the year, NCRP recommends that any one source or procedure should not produce more than 25% of this limit, or 250 uSv annually. This applies to all man-made sources of radiation, such as: smoke detectors, stray radiation from electronic equipment, nuclear power plants, and so on. For comparison, normal background radiation is also about 1,000 uSv per year at sea level, and twice that in Denver from the increased altitude.

#### **Radiation Dose Limit for Body Scanners**

NCRP and N43-17 require that body scanners operate within the dose levels already set for the General Public, the lowest category. That is, no person screened with body scanners will receive more than 250 uSv per year.

The “thin-person” setting on Intercept uses a radiation dose of 0.25 uSv per scan. That is, a person could be scanned up to 1,000 times per year on this setting. On the “heavy-person” setting the dose is 0.90 uSv, allowing up to 277 scans per year. Intercept keeps track of the accumulated dose each person receives to insure these requirements are met. The requirements can also be met by simply limiting the number of scans to the above values.

#### **Screening Pregnant Women**

It is widely recognized that pregnant women, children and various other individuals are more sensitive to radiation than other members of the public. Accordingly, the radiation limit for this subgroup is lower for both medical and occupational exposure. For instance, NCRP recommends that pregnant workers should receive less than 5,000 uSv during the pregnancy, about one-tenth that of a regular employee. These occupational exposure levels are primarily enforced by OSHA.

However, the radiation limit for the General Public, 250 uSv per year, is already more than 20 times lower than this occupational limit for pregnant workers. Further, NCRP and N43-17 make clear that the General Public category inherently includes pregnant women, children, and other special groups. That is, the dose recommendation for the General Public was intentionally made low enough to protect this subgroup of radiation sensitive persons.

Because body scanners operate within the General Public category, there is no justification in radiation safety for treating pregnant women differently than others, either as subjects or employees.

#### **Pregnant Employees**

NCRP and N43-17 provide that scanner operators and bystanders be treated as members of the General Public, with a maximum allowable dose of 250 uSv per year. They are not classified as radiation workers, and are not allowed the higher occupational dose level of OSHA regulations.

At four feet from the scanner, the closest an employee would normally stand, Intercept produces about 0.01 uSv per scan on the highest setting. That is, an employee could stand in this position for up to 25,000 scans conducted in one year.

There is little chance that any employee will exceed the 250 uSv annual limit in normal operation. Accordingly, Institutions generally do not need to enact procedures for radiation protection of employees, other than routine good practices. During training, operators are instructed to keep all personnel at least four feet away from the scanner during normal operation, but may occasionally stand closer if needed for an operational reason. Excluding pregnant employees from these duties or procedures is not warranted for radiation protection. This is also the stated position of the NCRP and N43-17.

### **Recommendations for Institutional Procedures**

Every Institution should strive to align its operational procedures with the N43-17 standard. This gives the Institution the backing of essentially every radiation protection organization in the United States. The primary requirement is that no person exceeds a radiation exposure of 250 uSv per year, including pregnant women, both as subjects and operators.

Of course, there are valid reasons why an Institution may refrain from scanning pregnant subjects, other than radiation safety. For instance, the fetus will appear in the scanned image during later portions of the pregnancy, presenting a variety of issues. If an Institution elects to avoid scanning pregnant women for such reasons, it should be cautious not to imply that it is done for the purpose of radiation safety.

Commissioners  
Randy T. Church, Chairman Michael  
W. LaBrose, Vice Chairman

Jeff Branch  
Donnie Potter  
Robbie Wilkie

Tony Helton, Interim County Manager



County of Caldwell  
PO Box 2200  
Lenoir, NC 28645  
Phone (828) 757-1300  
Fax (828) 757-1295

www.caldwellcountync.org

### AMERICAN RESCUE PLAN ACT REIMBURSEMENT FORM

Date: 8/23/2021

Project Title: Protective Measures Caldwell County Detention Facility - Body Scanner

( i.e. PPE, Disinfectant, Protective Measures, Payroll, Equipment etc.)

ARPA-11

**Project Description/Justification:**

The project for this grant is for the purchase and implementation of a system to completely search individuals that enter our Correctional Facility for illegal contraband. This system shall complete a full body scan to detect cell phones, weapons, and other items that can be hidden in body cavities or elsewhere on inmates or visitors.  
Systems such as this are currently in place in other facilities throughout NC but our facility does not own or operate one. Our current method for searching relies on the antiquated hands-on physical search by the correctional staff and utilizing non-reliable squat and cough methods for items hidden inside a body cavity.  
Even during the pandemic year of 2020, the Caldwell County Jail processed 4750 inmates. With an estimated time of a half hour per inmate this totals 2,875 hours of manpower spent. The systems that are now available require someone to stand still for 4 seconds and the process is over saving taxpayer money.  
There will be a minimum of eighteen agencies that will benefit from the purchase and use of this type of equipment in our facility. They range from the Federal Government since we house their inmates to our own local jurisdictions and probation and parole. By receiving the project approval the correction officers can remain at a social distance while ensuring that illegal contraband will not enter our facility.

Project Cost: \$ 169,000

(Attach Quote or Receipt)

Entity Requesting: Caldwell County Sheriff's Office

(County Government - Department)

[Signature]  
Authorized Official - Signature/Title

AC ✓  
8-23-21  
Approved

Denied

[Signature]  
Authorized Official (Consultant)

ARPA-11

Authorized Official (Caldwell County)

Mitigating the impact of COVID-19, including taking actions to control its spread and support hospitals and health care workers caring for the sick, continues to require a major public health response from State, local and Tribal governments. New or heightened public health needs include COVID-19 testing, major expansions in contact tracing, support for individuals in isolation or quarantine, enforcement of public health orders, new public communication efforts, public health surveillance (e.g., monitoring case trends and genomic sequencing for variants), enhancement to health care capacity through alternative care facilities, and enhancement of public health data systems to meet new demands or scaling needs. State, local, and Tribal governments have also supported major efforts to prevent COVID-19 spread through safety measures at key settings like nursing homes, schools, congregate living settings, dense worksites, incarceration settings, and in other public facilities. This has included implementing infection prevention measures or making ventilation improvements in congregate settings, health care settings, or other key locations.

Other response and adaptation costs include capital investments in public facilities to meet pandemic operational needs, such as physical plant improvements to public hospitals and health clinics or adaptations to public buildings to implement COVID-19 mitigation tactics. In recent months, State, local, and Tribal governments across the country have mobilized to support the national vaccination campaign, resulting in over 250 million doses administered to date.<sup>25</sup>

The need for public health measures to respond to COVID-19 will continue in the months and potentially years to come. This includes the continuation of the vaccination campaign for the general public and, if vaccinations are approved for children in the future, eventually for

---

<sup>25</sup> Centers for Disease Control and Prevention, COVID Data Tracker (COVID-19 Vaccinations in the United States, <https://covid.cdc.gov/covid-data-tracker/#vaccinations> (last visited May 8, 2021)).

**FEDERAL GRANTS - ARPA 2021**  
Budget Basis - Fiscal Year 2022

<b>Sources (REVENUES) On-Deposit</b>		FY2022	REVISED	AS OF	Encumbrances	Fund Balance	%
US TREASURY DISBURSEMENT		Appropriation	BUDGET	10/15/2021			Exp
Bank Interest				Expenditures			
20,165,915.00							
<b>TOTAL ARPA 2021 Sources REVENUE On-Deposit</b>		<b>20,165,915.00</b>					
<b>Uses (APPROPRIATION OF REVENUES)</b>							
<b>NCEU PREMIUM PAY</b>							
Salary/Wage	2,755,240.00	2,755,240.00	155,576.82		2,570,890.25		6.69%
Benefits	-	-	28,772.93				
<b>MOBILE VACCINE VEHICLE</b>							
Expenses	38,000.00	38,000.00	33,985.00		4,015.00		89.43%
<b>ARPA FINANCIAL PROJECT MANAGER</b>							
Salary/Wage	255,000.00	255,000.00	13,846.20		238,233.16		5.43%
Benefits	-	-	2,920.64				
<b>DEEDS PPE SAFETY ROOM OUTFIT</b>							
Expenses	12,000.00	12,000.00	12,049.00		(49.00)		100.41%
<b>ENGINEERING AND DESIGN GLOBAL</b>							
ENGINEERING AND DESIGN (08/04/21)	500,000.00	475,240.00			Unallocated		
SUPPLEMENTAL (10/06/21)	400,000.00	392,500.00			867,740.00		
<b>ENGINEERING AND DESIGN Allocated</b>							
COUNTY FACILITIES HVAC STUDY					Allocated		
Expenses	-	24,760.00	-		24,760.00		0.00%
WETLANDS DELINEATION SERVICES							
Expenses	-	7,500.00			7,500.00		100.00%
<b>MY TEEN PLACE CENTER</b>							
Expenses	1,500,000.00	1,500,000.00			1,500,000.00		0.00%
<b>TOTAL ARPA 2021 Uses (APPROPRIATIONS)</b>		<b>5,460,240.00</b>	<b>5,460,240.00</b>	<b>247,150.59</b>	<b>7,500.00</b>	<b>5,205,589.41</b>	<b>4.66%</b>

**Net Sources less Uses - On Deposit**

ARPA 2021 FUNDS UNDESIGNATED 14,705,675.00

**Awarded - Not Yet Received**

Accounts Receivable - Due from US Treasury<sup>1</sup> 20,165,915.00

<sup>1</sup> The total amount of funds awarded to York County is \$40,331,830, release of second disbursement is expected in early Calendar 2022.