

1 **COMMISSIONERS' WORKSHOP ON AMERICAN RESCUE PLAN FUNDING**

2 **SEPTEMBER 1, 2021**

3
4
5
6 ***YORK,ss***

7 At a workshop of the County Commissioners of the County of York, begun and holden at the York
8 County Government Building in Alfred, within and for the County of York, being held on
9 Wednesday, September 1, 2021 A. D. at 3:00 P. M.
10

11
12 **COMMISSIONERS PRESENT:**

13 Richard R. Dutremble
14 Richard Clark
15 Robert Andrews
16 Allen Sicard
17 Donna Ring (via ZOOM)
18

19 County Manager Gregory Zinser and Deputy County Manager Linda Corliss were present at the
20 workshop.
21

22 **YOU ARE INVITED TO RISE AND SALUTE THE FLAG OF THE UNITED STATES**

23 County Manager Zinser explained that the Commissioners would be reviewing and discussing
24 outside requests at this workshop; all of which appear on the County's website. He continued that
25 the themes that came forward from requests were: training for all hazards, mental and behavioral
26 health including detox, housing, communication, transportation and the purchase of a dredge from
27 some of the coastal cities and towns.

28 County Manager Zinser continued that regional partners would be a consideration in proceeding
29 with many of these projects. Another consideration is where, geographically, could these projects
30 be placed and the jail land seems to be a viable answer. He reminded the Commissioners that there
31 have been discussions only at this point with nothing approved as of yet.

32 The County Manager distributed a map to the Commissioners and explained that he is proposing
33 to develop 75 acres of the jail land. One of the proposals is for 35-40 units of housing for those
34 leaving incarceration, substance misuse treatment and others who are facing housing insecurity.
35 This project would be done in conjunction with Sanford Housing Authority.

36 Another proposal, explained County Manager Zinser, is for \$5 million to build a larger treatment
37 center and open this facility up to the community at large. Currently, Layman Way Recovery

78 County Manager Zinser replied that we will certainly have that conversation. He added the other
79 issue is we will have to get licensing from the Town of Alfred.

80 Commissioner Sicard commented that he echoes Commissioner Clark's comments about funding
81 and that he would certainly like to see the State involved since they have the money.

82 County Manager Zinser stated that he can reach out to the Governor's office to see if they would
83 give us money similar to the MAT program at the jail.

84 Commissioner Clark asked if we were to build a new center, could we do it without detox? Could
85 the detox take place off-site? County Manager Zinser replied that it could but there is a shortage
86 of detox facilities in Maine, particularly in York County.

87 County Manager Zinser stated that the next proposal is for a regional training facility on 17 acres
88 of the (jail) land. He continued that the Commissioners have heard from several town managers,
89 police and fire chiefs that there is a need for a regional training center. The County Manager added
90 that there is a staffing difficulty in these fields that the pandemic exasperated. We are proposing
91 creating a jobs program in conjunction with York County Community College and Sanford Vo-
92 Tech. This facility could also have police, paramedic and firefighter simulator labs. This is lacking
93 in the State of Maine as well.

94 A regional career development and training center would have positive impacts for recruitment
95 and retention for new firefighters and police, stated the County Manager. This center is highly
96 desired by all of our Police and Fire Chiefs and EMS personnel for local training. The County has
97 already been working on this and are hiring fire instructors.

98 Chief Schools, President of York County Fire Chiefs' Association spoke to voice support and
99 remind the Commissioners of the support they have received from York County Fire Chiefs. This
100 center would alleviate us having to send our firefighters an hour or more away for training and
101 provide a place for firefighters and police officers to learn to drive the emergency vehicles as well
102 as learn how to be an EMT. Chief Schools continued that they support this initiative for the
103 betterment of the workforce as well as the betterment of working together as a county.

104 Chief Hooper stated that this center would allow us to leverage other assets around the State. He
105 added that every York County community already has a relationship with the community college
106 system.

107 Kate Grant, Director of Workforce Development at York County Community College in Wells
108 addressed the Board and stated that the EMS program at York County Community College was
109 recently developed. There is a high need for EMS training and continued professional
110 development for retention. A space dedicated for "hands on" training is needed.

111 Professor Willis who has taught at SMCC for 39 years spoke in support of the training center. He
112 stated that he has seen declining numbers in these fields and that this proposal is a collaboration
113 and a ray of hope for the future of emergency services.

114 Wells Police Chief and York County Chief's Association President, Jo-Ann Putnam addressed the
115 Board and thanked the Commissioners for their consideration of the training facility. She added

153 County Manager Zinser stated that our communications tower in Acton is failing and there are no
154 funds to replace it. This tower carries County fire. There is not only the cost of the tower, stated
155 County Manager Zinser, but also the cost of the repeater and back up dispatch here at the County.
156 He added that these are allowable uses of the ARPA money.

157 Chief Hooper informed the Commissioners that York County has twelve different dispatch
158 agencies. If one goes down, they could move their operations to our backup site. The Acton tower
159 site is very vital for fire services.

160 Commissioner Clark asked if there is an opportunity to put another tower at the same location as
161 the cost is not cheap to build a new one.

162 EMA Director Art Cleaves replied that this is not possible for these frequencies.

163 Commissioner Sicard asked if there was a cost estimate for the replacement of the Acton tower.

164 County Manager Zinser replied, \$1.4 to \$1.5 million.

165 Commissioner Andrews asked if anyone had looked into a lease from cellular towers?

166 County Manager Zinser replied that none have expressed interest and that the property owner does
167 not want cellular.

168 Commissioner Clark asked if we owned the land. County Manager Zinser replied that we do not
169 and that at one time we had a lease but that has expired. The land owner has expressed interest in
170 selling the land.

171 Commissioner Dutremble closed the Workshop.

172

173

174

1 **COMMISSIONERS MEETING**

2 **September 1, 2021**

3
4
5 *YORK,ss*

6
7 At a regular meeting of the County Commissioners of the County of York, begun and
8 holden at the York County Government Building in Alfred, within and for the County of York, being held
9 on Wednesday, September 1, 2021 A. D. at 4:30 P. M.

10
11
12 **COMMISSIONERS PRESENT:**

- 13
- 14 Richard R. Dutremble
- 15 Richard Clark
- 16 Robert Andrews
- 17 Allen Sicard
- 18 Donna Ring (via ZOOM)
- 19
- 20
- 21
- 22

23 County Manager Gregory Zinser and Deputy County Manager Linda Corliss were present at the meeting.

24
25
26 **YOU ARE INVITED TO RISE AND SALUTE THE FLAG OF THE UNITED STATES**

27
28
29 **09-01-21 ITEM**

30 County Manager Zinser informed the Commissioners that Item 6F will be taken off
31 from the agenda and an executive session pursuant to 1 M.R.S.A. §405 (6) (C), acquisition of
32 real property or economic development, will be added to the agenda

33
34 **1 PUBLIC COMMENT(S) ON ANY ITEM(S)**

35 Chief Rod Hooper addressed the Board to inform all that Saco Fire Chief,
36 John Duross was named Maine Fire Chief of the Year. He added that in an
37 after action review of line of duty deaths, Berwick Chief Plante mentioned the
38 York County Incident Management Team as helpful.

39
40 **2 TO APPROVE THE MINUTES OF THE FOLLOWING MEETINGS:**

- 41 a. Workshop of August 4, 2021-
- 42 Commissioner Clark motioned to approve the minutes. Commissioner Sicard
- 43 seconded the motion. Vote 4-0. (Commissioner Ring not allowed to
- 44 participate in voting due to State law as explained by C.M. Zinser)
- 45 b. Regular Meeting of August 4, 2021-
- 46 Commissioner Clark motioned to approve the minutes. Commissioner Sicard
- 47 seconded the motion. Vote 4-0.
- 48
- 49

50 **3 TO APPROVE TREASURER’S WARRANTS**

51
52
53
54
55
56
57
58
59
60
61
62
63
64
65
66
67
68
69
70
71
72
73
74
75
76
77
78
79
80
81
82
83
84
85
86
87
88
89
90
91
92
93
94
95
96
97
98
99
100

- a. Warrants dated August 4, 2021 in the amount of \$945,231.28
Commissioner Clark motioned to approve the warrant. Commissioner Sicard seconded the motion. Vote 4-0.
- b. Warrants dated August 11, 2021 in the amount of \$385,819.73
Commissioner Clark motioned to approve the warrant. Commissioner Sicard seconded the motion. Vote 4-0.
- c. Warrants dated August 18, 2021 in the amount of \$481,614.91
Commissioner Clark motioned to approve the warrant. Commissioner Sicard seconded the motion. Vote 4-0.
- d. Warrants dated September 1, 2021 in the amount of \$282,957.86
Commissioner Clark motioned to approve the warrant. Commissioner Sicard seconded the motion. Vote 4-0.

4 TO HEAR ANY REPORTS FROM THE COUNTY COMMISSIONERS

None

5 TO HEAR ANY REPORTS FROM THE COUNTY MANAGER

None

6 NEW BUSINESS

- a. Introduce H.R. Director Linda Corliss to obtain hiring approval of the following individuals:
 - i. Hiring of Nathan Thayer in the position of Jail Administrator with a hire date of September 6, 2021-
DISCUSSION: Commissioner Ring asked if Mr. Thayer resided in York County. H.R. Director Corliss stated that he did not but that was not a requirement of the position. Commissioner Ring asked if he would be given a county vehicle. County Manager Zinser replied that he would be. H.R. Director Corliss informed all that Mr. Thayer's salary is \$105,000.00. Commissioner Clark motioned to approve the hiring of Nathan Thayer in the position of Jail Administrator with a hire date of September 6, 2021. Commissioner Sicard seconded the motion. Vote 4-0.
 - ii. Hiring of Steven Coombs in the position of Disaster Assistance Responder III in EMA with a hire date of September 2, 2021-
Commissioner Clark motioned to approve the hiring of Steven Coombs in the position of Disaster Assistance Responder III in EMA with a hire date of September 2, 2021. Commissioner Sicard seconded the motion.
DISCUSSION- Commissioner Ring asked in the reserve status guarantees a certain number of hours per week. H.R. Director Corliss replied it does not. They are used on an "as needed" basis. Vote 4-0.
 - iii. Hiring of Kristen Garvin in the position of Disaster Assistance Responder II in EMA with a hire date of September 2, 2021
Commissioner Clark motioned to approve the hiring of Kristen Garvin in the position of Disaster Assistance Responder II in EMA with a hire date of September 2, 2021. Commissioner Sicard seconded the motion. Vote 4-0.
 - iv. Hiring of William Sakal in the position of Disaster Assistance Responder II with a start date of September 2, 2021-
Commissioner Clark motioned to approve the hiring of William Sakal in the

101 position of Disaster Assistance Responder II in EMA with a start date of
102 September 2, 2021. Commissioner Sicard seconded the motion. Vote 4-0.
103 v.Hiring of Rebecca Gaillard in the position of Disaster Assistance Responder
104 II with a start date of September 2, 2021-
105 Commissioner Clark motioned to approve the hiring of Rebecca Gaillard in the
106 position of Disaster Assistance Responder II with a start date of September 2,
107 2021. Commissioner Sicard seconded the motion. Vote 4-0.
108 vi.Hiring of Elizabeth Martin in the position of Disaster Assistance
109 Responder II with a start date of September 2, 2021-
110 Commissioner Clark motioned to approve the hiring of Elizabeth Martin in the
111 position of Disaster Assistance Responder II in EMA with a start date of
112 September 2, 2021. Commissioner Sicard seconded the motion. Vote 4-0.
113 vii.Hiring of Elizabeth Hillman-Garriepy in the position of Disaster Assistance
114 Responder II with a start date of September 2, 2021-
115 Commissioner Clark approved the hiring of Elizabeth Hillman-Garriepy in the
116 position of Disaster Assistance Responder II in EMA with a start date of
117 September 2, 2021. Commissioner Sicard seconded the motion. Vote 4-0.
118 DISCUSSION- Commissioner Clark commented that EMA has (vaccination)
119 Clinics scheduled almost everyday for the next few weeks. He added that he
120 would like to commend them on their hard work.
121 County Manager Greg Zinser commented that he would also like to show his
122 appreciation for EMA. He informed all that there will be booster clinics as
123 well.
124 c. Commissioner review and vote on Arundel Contract Deputy Agreement-
125 County Manager Zinser stated that both this contract and the Parsonsfield one
126 are renewals and have been approved by the towns already. Arundel's
127 contract is for two deputies.
128 Commissioner Ring asked if there were any changes made to the contracts.
129 County Manager Zinser stated that there were some minor non-substantive
130 wording changes and that the contracts had been reviewed by the county's
131 legal counsel.
132 Commissioner Clark motioned to approve the Arundel contract and authorize
133 the County Manager to sign. Commissioner Sicard seconded the motion.
134 Vote 4-0.
135 d. Commissioner review and vote on Parsonsfield Contract Deputy Agreement-
136 Commissioner Clark motioned to approve the Parsonsfield contract and
137 authorize the County Manager to sign it. Commissioner Sicard seconded the
138 motion. Vote 4-0.
139 e. Commissioner review and vote on Food Pantry Lease-Commissioner Clark
140 asked if there had been any changes made to this lease. County Manager
141 Zinser replied there has not.
142 Commissioner Clark motioned to approve the contract and authorize the
143 County Manager to sign it. Commissioner Sicard seconded the motion.
144 Vote 4-0.
145 f. Commissioner review and vote on jail shower project quote-*taken off the
146 agenda**
147 g. Commissioner review and possible vote on jail campus driveway repairs-
148 County Manager Zinser introduced Facilities Manager Rick DeRochemont to
149 discuss. Manager DeRochemont explained that the county's plow contractor
150 had expressed some concerns over the past winter about the condition of the
151 jail campus driveways to include pot holes that have since been filled. He

152
153
154
155
156
157
158
159
160
161
162
163
164
165
166
167
168
169
170
171
172
173
174
175
176
177
178
179
180
181
182
183
184
185
186
187
188
189
190
191
192
193
194
195
196
197
198
199
200
201
202

explained that he obtained three quotes and recommends Armour Guard as they also provide striping of the parking lots in their quote.

Commissioner Clark motioned to award the bid to Armour Guard in the amount of \$34,990.00. Commissioner Sicard seconded the motion. Vote 4-0.

h. Possible action(s) on American Rescue Plan Act funds-

County Manager Zinser explained to the Commissioners that he needs some direction on a couple of items previously discussed at the workshop. The first being the sewer. He stated that he has been invited to the Sanford Sewer District on September 13th to inform them as to what the County is planning. He asked the Commissioners if they are okay with him moving forward with the recovery center and housing. If so, he continued, he can then go to the engineer and get information. The other item is the back up terminal as well as the tower.

Commissioner Clark replied that he is fine with the County Manager talking with the Sanford Sewer District and spending the money on the engineering. But, he asked, if we can build our own system for \$5 million, why would we spend \$9 million to get public sewer? Commissioner Clark added that we need to consider there will also be sewer user rates on top of that as an ongoing cost. He continued that before we move forward with this, we would be well advised to talk about the costs. Anything we propose to build, stated Commissioner Clark, we need to build as energy efficient as possible. He continued that he has lots of questions for later regarding the sewer route.

Commissioner Sicard commented that having the public sewer line pass by for four or five miles will open up a whole corridor. We could possibly save some money by having others hook into the sewer.

County Manager Zinser stated that yes, there are a lot of possible opportunities and further negotiations with the sewer district.

Commissioner Andrews asked if it would be possible to build a small sewerage system at the jail and other same areas around here.

Commissioner Dutremble stated that he agreed with the other Commissioners that we should definitely get revenues from the public sewer line.

County Manager Zinser confirmed that the Commissioners are requesting on some items a committee be formed, for example the training center.

Commissioner Clark replied yes, they would like the County Manager to come back with more information at the next meeting on housing, additional opioid treatment beds to include converting the current recovery center into a detox facility and a training facility. He added that he would like included, the charge for the committee to complete items along with a schedule of completion for those items. Commissioner Clark added that each project should have different individuals on each committee. He continued that a committee is not necessary for the tower and dispatch, just a vote of the Commissioners.

Commissioner Ring suggested the Board begin to look into the tower replacement as that is very important.

County Manager Zinser stated that he would be asking for specific authorization in the amount of \$1.4 million.

Commissioner Andrews stated that he would want an assurance of a 99 year lease from the land- owner.

Commissioner Andrews motioned to move forward with gathering more information regarding the tower replacement in the amount of \$1.4 million.

Vote 4-0.

203
204
205
206
207
208
209
210
211
212
213
214
215
216
217
218
219
220
221
222
223
224
225
226
227
228
229
230
231
232
233
234
235
236
237
238
239
240
241
242

7 OLD BUSINESS

None

8 TO CONDUCT AN EXECUTIVE SESSION ON PERSONNEL ISSUES PURSUANT TO 1 M.R.S.A. §405 (6) (A), ACQUISITION OF REAL PROPERTY OR ECONOMIC DEVELOPMENT PURSUANT TO 1 M.R.S.A. § 405 (6) (C), LABOR NEGOTIATIONS PURSUANT TO 1 M.R.S.A. § 405 (6) (D) AND CONSULTATION WITH LEGAL COUNSEL PURSUANT TO 1 M.R.S.A. § 405 (6) (E), REVIEW OF CONFIDENTIAL RECORDS PURSUANT TO 1 M.R.S.A. § 405 (6) (F)

- a. Enter into executive session pursuant to 1 M.R.S.A. § 405 (6) (D) labor Negotiations-
Commissioner Clark motioned to enter into executive session pursuant to the above-noted statute. Commissioner Sicard seconded the motion. Vote 4-0.
Commissioner Clark motioned to come out of executive session. Commissioner Sicard seconded the motion. Vote 4-0.
No action taken.
- b. Enter into executive session pursuant to 1 M.R.S.A. §405 (6) (A) personnel Issues-
Commissioner Clark motioned to enter into executive session pursuant to the above-noted statute. Commissioner Sicard seconded the motion. Vote 4-0.
Commissioner Clark motioned to come out of executive session. Commissioner Sicard seconded the motion. Vote 4-0.
No action taken.
- c. Enter into executive session pursuant to 1 M.R.S.A. §405 (6) (C) acquisition of real property or economic development-
Commissioner Clark motioned to enter into executive session pursuant to the above-noted statute. Commissioner Sicard seconded the motion. Vote 4-0.
Commissioner Clark motioned to come out of executive session. Commissioner Sicard seconded the motion. Vote 4-0.
No action taken.

9 PUBLIC COMMENT(S) ON ANY ITEM(S)

None

10 ADJOURN

Commissioner Clark motioned to adjourn. Commissioner Sicard seconded the motion. Vote 4-0.

COMMISSIONERS MEETING

September 10, 2021

YORK,ss

At a special meeting of the County Commissioners of the County of York, begun and holden at the York County Government Building in Alfred, within and for the County of York, being held on Friday, September 10, 2021 A. D. at 8:00 A. M.

COMMISSIONERS PRESENT:

Richard R. Dutremble (excused)
Richard Clark
Robert Andrews (excused)
Allen Sicard
Donna Ring

County Manager Gregory Zinser and Deputy County Manager Linda Corliss were present at the meeting.

YOU ARE INVITED TO RISE AND SALUTE THE FLAG OF THE UNITED STATES

09-10-21 ITEM

1 NEW BUSINESS

a. Introduce H.R. Director Linda Corliss to request the hiring of the following individuals:

i. Nicholas Raucci in the position of a full-time Corrections Officer with a hire date of September 13, 2021

Commissioner Clark motioned to approve the hiring of Nicholous Raucci in the position of full-time Corrections Officer with a hire date of September 13, 2021.

Commissioner Ring seconded the motion.

DISCUSSION: Commissioner Ring asked Sheriff King if he has approved all of these hirings. Sheriff King responded that he had.

Vote 3-0.

ii. Anthony Marston in the position of a full-time Corrections Officer with a hire date of September 13, 2021

Commissioner Clark motioned to approve the hiring of Anthony Marston in the position of full-time Corrections Officer with a hire date of September 3, 2021.

Commissioner Ring seconded the motion. Vote 3-0.

iii. Christopher Saiauski in the position of a reserve Corrections Officer with a

hire date of September 13, 2021
Commissioner Clark motioned to approve the hiring of Christopher Saiauski in the position of reserve Corrections Officer with a start date of September 13, 2021. Commissioner Ring seconded the motion. Vote 3-0.

iv. Kristen Garvin to transfer from Disaster Assistance Responder II to Disaster Assistance Responder III in EMA with an effective date of September 13, 2021
Commissioner Clark motioned to approve the transfer of Kristen Garvin from Disaster Assistance Responder II to Disaster Assistance Responder III with an effective date of September 13, 2021. Commissioner Ring seconded the motion. Vote 3-0.

2 PUBLIC COMMENT(S) ON ANY ITEM

None

3 ADJOURN

Commissioner Clark motioned to adjourn. Commissioner Ring seconded the motion. Vote 3-0.

Meeting adjourned at 8:09 a.m.

DRAFT



COUNTY OF YORK

Robert L. Andrews
District 1

Richard R. Dutremble
Chairperson
District 2

Allen R. Sicard
Vice-Chairperson
District 3

Donna L. Ring
District 4

Richard Clark
District 5

45 Kennebunk Road
Alfred, Maine 04002

(207) 459-2313
Fax (207) 324-9494
YC-Commish@yorkcountymaine.gov

Gregory T. Zinser
County Manager

Kathryn A. Dumont
Assistant to the Manager

Linda M. Corliss
Deputy County Manager
Human Resource Director

Lorene B. Lemieux
Finance Director

There could be no better time to invest in our public safety agencies and first responders. We've seen years of declining numbers of Fire, EMS, and Law Enforcement personnel. This has been exacerbated by the global pandemic. Our public safety agencies have done an admirable job on the front line in an ever-changing response to the COVID-19 pandemic. We need to ensure that we recruit and retain high caliber candidates for these positions now and in the future. We must ensure that our first responders, emergency planners, public health professionals, utility workers, and others, have the facilities and opportunities to plan, prepare and respond to public emergencies of all types.

This proposal responds directly to one of the major categories of allowed uses under the American Rescue Plan Act. As a response to the public health emergency, we have seen the effects that COVID-19 has the staffing of our public safety, health care, utility, 911 centers, and emergency management agencies. We have witnessed entire fire departments quarantined. This places a huge burden on an already stressed mutual aid system.

The speed with which the pandemic hit, coupled with the rate at which policy and procedural guidance changed, severely hindered our public safety agencies to plan and prepare their response. There was no ability to properly train on the full range of COVID-19 best practices by individual agencies or at the interagency-level.

During the first phase of vaccine distribution, the York County Incident Management Team organized. This team was responsible for developing a plan for vaccine distribution at the local level. This mission was highly successful, yet shortcomings have been noted. A site for logistic operations was needed. A location to stage material, conduct planning, set up a central point of distribution would have increased operational efficiency.

Accordingly, in response to a public emergency, known threats and emerging threats, York County will invest in the creation of a centralized facility that will support two functions:

1) The strategic **planning** of emergency operations. The **preparation** of our first responders, public health professionals, utility workers, emergency planners, and others. The staging of material and equipment in **response** to a public health emergency, natural disaster, civil disturbance, or other public safety event.

2) The **training, readiness, and development** of our public safety workforce. In cooperation with public safety, emergency management, public health, allied professionals, and the Community College System of Maine. Emphasize the **recruitment and retention** of high caliber individuals into public safety occupations.

This facility will be of a sufficient size and scope to provide an “All Hazards” approach for the training and professional development of our first responders. Allowing for improved interagency coordination, collaboration, and communications. It will be a ready site for creating points of distribution or dissemination to support operations for mobile capabilities (For example, mobile vaccine teams). The facility will also provide a site for larger scale, longer term, or semi-permanent capabilities. (For example; mass vaccination, material staging, mass feeding, and others). This would negate the need for renting commercial sites.

This investment will signal broadly to the citizens of York County, that their county government is committed to their safety, and the ability of their first responders to continue to manage the COVID-19 pandemic and what other events the future may hold.

The County Commissioners are in agreement and order that a committee be established consisting of:

- (2) Police Chiefs as assigned by Maine Chiefs’ of Police Association - District One;
- (2) Fire Chiefs as assigned by the York County Chiefs’ Association;
- (2) members of the Community College System, representing workforce development and emergency medicine, as assigned by the System President;
- (1) Maine CDC York County District Liaison;
- (2) County Commissioners;
 - County Manager;
 - EMA Director;
 - County Fire Administrator.

This committee will be charged with the overall planning and development of a strategic training and readiness center for York County. The committee will prepare a report that will include design, engineering, capabilities, and program specifications along with proposed operating needs. This committee will report as soon as possible within and according to the constraints of the American Rescue Plan Act.

So ordered by the County Commissioners of the County of York.

Chairman Richard R. Dutremble

Vice-Chairman Allen R. Sicard

Richard Clark

Robert L. Andrews

Donna L. Ring



COUNTY OF YORK

Robert L. Andrews
District 1

Richard R. Dutremble
Chairperson
District 2

Allen R. Sicard
Vice-Chairperson
District 3

Donna L. Ring
District 4

Richard Clark
District 5

45 Kennebunk Road
Alfred, Maine 04002

(207) 459-2313
Fax (207) 324-9494
YC-Commish@yorkcountymaine.gov

Gregory T. Zinser
County Manager

Kathryn A. Dumont
Assistant to the Manager

Linda M. Corliss
Deputy County Manager
Human Resource Director

Lorene B. Lemieux
Finance Director

Being a County Government, York County is uniquely situated and well positioned to respond to the public health emergency by building and expanding upon our current programs aimed at substance misuse treatment and mental health treatment. The County desires to build a large treatment and recovery center and convert the current center into a detox center and coordinate the development of a 35 to 40 unit housing complex with Sanford Housing Authority. Substance misuse and mental/behavioral health are problems that have been exacerbated by COVID-19. In Maine alone, we have seen over 500 overdose deaths. We heard from a local fire chief who recounted his agency's response to three back-to-back overdose deaths. The County Commissioners are in concurrence that substance misuse, behavioral health, housing and the need for detox have been impacted by COVID-19 and that need to provide services is greater now than it has ever been.

Therefore, the County Commissioners authorize the formation of multiple committees: a building committee as well as a committee to discuss behavioral health programming. There will be, and should be, dual memberships on committees recognizing the interconnectedness of building designs on therapeutic treatment.

Proposed committee structures

Building Committee

- Executive Director of Sanford Housing Authority
- County Manager
- One County Commissioner
- A Clinician holding a L.A.D.C. and C.C.S. license with experience in program operations/development
- CDC Local Public Health Liaison

Behavioral Health Committee

- District Attorney
- York County Sheriff or designee

- One member of the York County Police Chiefs Association for District 1
- One member from the York County Fire Chiefs Association
- CDC local public health liaison
- County Manager
- One Commissioner
- A Clinician holding a L.A.D.C. and C.C.S. license with experience in program operations and development
- Executive Director of Sanford Housing Authority

Each of these committees should confer with one another and should seek the advice of subject matter experts as needed or recommend to the County Commissioners if further membership opportunities are needed.

These committees will be charged with the overall planning and development of a treatment and recovery center, detox facility and housing. These committees will prepare a report that will include design, engineering, capabilities, and program specifications along with proposed operating needs. This committee will report as soon as possible within and according to the constraints of the American Rescue Plan Act.

So ordered by the County Commissioners of the County of York.

Chairman Richard R. Dutremble

Vice-Chairman Allen R. Sicard

Richard Clark

Robert L. Andrews

Donna L. Ring

Xybix Systems, Inc.
 8207 SouthPark Circle
 Littleton CO 80120
 Phone: 303-683-5656
 Fax: 303-683-5454
 meghand



Quote Number: 29405

Quote Date: 9/9/2021
 Revision: A
 Orig Create Date: 9/8/2021
 Expires: 12/7/2021
 Opp #: 0025103

Quote

Terms: 50% DEP;40% INSTALL;10% PUNCH

Page: 1 of 3

<p>QUOTE TO: Acct: YORCOUALME York County EMA 149 Jordan Springs Rd Alfred ME 04002 Phone: Email:</p>	<p>SHIP TO: York County EMA 149 Jordan Springs Rd Alfred, ME 04002 USA Salesperson: SUSANNE LOTTIE Phone: (207) 343-1229 Email: susannel@xybix.com</p>
--	---

Standard 2021-9 Price List
 EAGLE LINE
 * TAX EXEMPT

08.17.2021 R0: Drawing Creation. MND

Pandemic Freight Surcharge: This fee is the temporary upcharge we are experiencing for shipping related costs and delays

Line	Part Num	Desc	Qty	U/M	List Ea.	Disc. %	Disc. Price	Net Price
1.00	14145-BLK	Cable Pole 96" - Alum Black	1	4.00 EA	\$130.00	50.00 %	\$65.00	\$260.00
1.01	15335	Cable Pole Trim Kit Top and Bottom Aluminum Black	2	4.00 EA	\$32.00	50.00 %	\$16.00	\$64.00
2.00	C-14498-3D.	Adj. Table Worksurface - Straight Single Surface - 66W x 40D - Cable Management Included	3	3.00 EA	\$1,847.00	50.00 %	\$923.50	\$2,770.50
3.00	15701	L4 Table Base	4	3.00 EA	\$6,736.00	50.00 %	\$3,368.00	\$10,104.00
4.00	16747.	Monitor Mount 3 - Fixed on WS - Straight Single Surface - 66W x 40D 16676 - Std VESA Mount 2 HI 2 Knuckle Qty = 2 Total: \$1,720.00	5	3.00 EA	\$3,307.00	50.00 %	\$1,653.50	\$4,960.50
5.00	13729	Ext Monitor Cable 25' VGA High Quality Male/Female	6	12.00 EA	\$104.00	50.00 %	\$52.00	\$624.00
5.01	16275	Datadock2 - Single Surface - Cable Organizer - 8 USB, 1 RJ45	7	3.00 EA	\$885.00	50.00 %	\$442.50	\$1,327.50
5.02	11996	Ext. Cable USB Type A to Type A Extension & Booster 5M (16' 4")	8	8.00 EA	\$125.00	50.00 %	\$62.50	\$500.00
6.00	11792-BLK	Power Bar - 10 Outlet With Black Sticker	9	3.00 EA	\$170.00	50.00 %	\$85.00	\$255.00
6.01	11792-OR	Power Bar - 10 Outlet With Orange Sticker	10	3.00 EA	\$170.00	50.00 %	\$85.00	\$255.00

Xybix Systems, Inc.
 8207 SouthPark Circle
 Littleton CO 80120
 Phone: 303-683-5656
 Fax: 303-683-5454
 meghand



Quote Number: 29405

Quote Date: 9/9/2021
 Revision: A
 Orig Create Date: 9/8/2021
 Expires: 12/7/2021
 Opp #: 0025103

Quote

Terms: 50% DEP;40% INSTALL;10% PUNCH

Page: 2 of 3

Item #	Description	QTY	EA	Unit Price	Disc %	Net Price	Ext. Price
7.00	CPNT. Table Components 16709 - Task Lights - \$519.00	11	3.00 EA	\$519.00	50.00 %	\$259.50	\$778.50
10.00	12030-3D. Return Worksurface - 30.25Wx23D	13	1.00 EA	\$491.00	50.00 %	\$245.50	\$245.50
10.01	12034-3D. Return Worksurface - 54.25Wx28.25D	14	1.00 EA	\$822.00	50.00 %	\$411.00	\$411.00
10.02	12033-3D. Return Worksurface - 18Wx36D	12	3.00 EA	\$656.00	50.00 %	\$328.00	\$984.00
11.00	15709 Cable Bridge Straight Left Side	15	2.00 EA	\$261.00	50.00 %	\$130.50	\$261.00
11.01	15710 Cable Bridge Straight Right Side	16	1.00 EA	\$261.00	50.00 %	\$130.50	\$130.50
11.02	13629-3D. CPU Cabinet - Tech Tower 18Wx48H Left Access with Sliding Shelf	17	1.00 EA	\$2,490.00	50.00 %	\$1,245.00	\$1,245.00
11.03	13629-3D. CPU Cabinet - Tech Tower 18Wx48H Right Access with Sliding Shelf	18	1.00 EA	\$2,490.00	50.00 %	\$1,245.00	\$1,245.00
11.04	13629-3D. CPU Cabinet - Tech Tower 18Wx48H No Additional Access with Sliding Shelf	28	1.00 EA	\$2,490.00	50.00 %	\$1,245.00	\$1,245.00
12.00	11093-3D. Drawer Pedestal - Mobile - Single - 16W - 6-6-12 Drawers 16W 18D	19	1.00 EA	\$1,330.00	50.00 %	\$665.00	\$665.00
12.01	11352-3D. Drawer Pedestal - Fixed - Single - 18W - 6-6-12 Drawers 18W 22D - Ext. Back & Right	20	1.00 EA	\$1,404.00	50.00 %	\$702.00	\$702.00
12.02	11352-3D. Drawer Pedestal - Fixed - Single - 18W - 6-6-12 Drawers 18W 22D - Ext. Back	21	1.00 EA	\$1,404.00	50.00 %	\$702.00	\$702.00
18.00	11099-3D. Under Return End Support	22	4.00 EA	\$295.00	50.00 %	\$147.50	\$590.00
18.01	12235 Support - "L" Bracket 18"	23	5.00 EA	\$55.00	50.00 %	\$27.50	\$137.50
18.02	10005 Table Support leg	24	1.00 EA	\$97.00	50.00 %	\$48.50	\$48.50
18.03	14655 Wall Screw Anchor Kit	25	2.00 EA	\$15.00	50.00 %	\$7.50	\$15.00
90.00	16139 Installers Kit Eagle Line	26	3.00 EA	\$0.00	50.00 %	\$0.00	\$0.00
99.00	Other Other Charges & Services	27	1.00 EA	\$0.00	0.00 %	\$0.00	\$0.00

Line (27) - Miscellaneous Charge -

Description	Ext. Price
1.) Freight	7,250.00
2.) Installation	6,886.50
3.) Pandemic Freight Surcharge	610.52

Xybix Systems, Inc.
 8207 SouthPark Circle
 Littleton CO 80120
 Phone: 303-683-5656
 Fax: 303-683-5454
 meghand



Quote Number: 29405

Quote Date: 9/9/2021
Revision: A
Orig Create Date: 9/8/2021
Expires: 12/7/2021
Opp #: 0025103

Quote

Terms: 50% DEP;40% INSTALL;10% PUNCH

Page: 3 of 3

Line	Part Num	Desc	Qty	U/M	List Ea.	Disc. %	Disc. Price	Net Price
		List Price Total:			\$61,052.00			
				Lines Total:				\$30,526.00
				Line Miscellaneous Charges				
				Total:				\$14,747.02
				Taxes Total:				\$0.00
				Quote Total:				\$45,273.02

Note 1:
 All quoted taxes are estimated. Any applicable taxes, fees, permits, etc. must be added to this quote.

Note 2:
 Where installation is listed on quote it is based in non-union labor and on one trip for installation only. Client is responsible for coordination of Technicians and other Vendors/Contractors. Waiting time will be charged at the rate of \$75 per man hour straight time and \$115 per man hour for OT plus subsistence expenses.
 Additionally, this quote is based upon a remodel in an existing space and/or new building - completely finished with a Certificate of Occupancy. Any project where the General Contractor is still on the job is subject to additional charges.

We appreciate this opportunity to provide this quote. Our goal is to substantially improve working conditions for your valuable staff. We look forward to meeting with you to review this proposal in detail. In the meantime please don't hesitate to call us with any questions.

xybix
 8207 SouthPark Circle
 Littleton, CO 80120
 1.800.788.2810 F.303.683.5454
 www.xybix.com

Sales : Susanne Lottie
 Email : Susannel@xybix.com
 Designer : Meghan Dinardi
 Email : MeghanD@xybix.com

York County EMA
 149 Jordan Springs Rd
 Alfred, ME 04002



Opportunity: 0025103
 Drawing Name:
 COVER PAGE
 SHEET: 1 of 4 SCALE: 1/2" = 1'-0"
 NOTE: This design & layout is the property of XYBIX Systems, Inc. & is not to be used in any written manner without express written permission by XYBIX Systems, Inc.
 Sign-Off Initials: REV X
 0

FINISH SELECTIONS		REVISIONS	
REV	DESCRIPTION	DATE	DSGN MIND
0	Drawing Creation	08.17.21	

Panel Trim : N/A
 Panel Fabric Upper : N/A
 Panel Fabric Lower : N/A
 3D Laminate Counter : Dackor Rock, Concrete A017
 3D Laminate Drawer&Door Front : surf(x) Matte Luxe, Black 536745
 Melamine : Panolam Pluswood 90S Black Chamois
 Edgeband : Panolam Pluswood 90S Black match
 Handle : Eagle Silver
SIGN OFF APPROVAL: Furniture orders and product installation shall not proceed until the Client has given approval to these documents. Approval of the Client shall constitute approval of the drawings for contents, scope of work and all dimensions regarded by the Client as being necessary to the use of space, furnishings and equipment. Furniture orders, or product installation authorized by the Client from these documents, shall be interpreted by XYBIX as approval in full to these documents by the Client. Revisions after approval shall result in additional costs.
 Signature: _____ Title: _____
 Date: _____

Sales : Susanne Lottie
 Email : Susannel@xybix.com
 Designer : Meghan Dinardi
 Email : MeghanD@xybix.com

York County EMA
 149 Jordan Springs Rd
 Alfred, ME 04002

Opportunity: 0025103
 Drawing Name:
TYPICAL WORKSTATION
 SHEET: SCALE:
 3 of 4 As indicated
 NOTE: This design & layout is the property of XYBIX Systems, Inc. & is not to be used in any written manner without express written permission by XYBIX Systems, Inc.
 Sign-Off Initials: REV **0**

Xybix 66"x40" Single Surface Console with true sit to stand adjustment range of 22"-48" AFF, with L4 Table Base.

Control System (max 2 Components)
 • **Task Light:** (2) Dimmable lights with flexible mounting arm on keyboard surface

Data Dock - Keyboard surface cable organizer
 (8) USB Ports
 (1) CAT6 Port

"RollerVision" Monitor Mounting system capable of 10" of focal depth adjustment. Accommodates up to (2) 24" flat panel monitors on a single level. Additional mounts will be added to stack a second tier of (2) 24" monitors

Cable Management Bridge for cable organization from desk to CPU cabinet
NOTE: Not a shelf

Under fixed work surface, Drawer Pedestal 18"W with 6", 6", 12" drawers

(3) CPU Enclosure, 48" high, Tech Tower with front and side locking access doors,
 (2) easy access pullout shelves and
 (2) silent 45 CFM fans for active ventilation.
Maximum CPU dimension: (3) 18" H x 7.5" W x 18" D

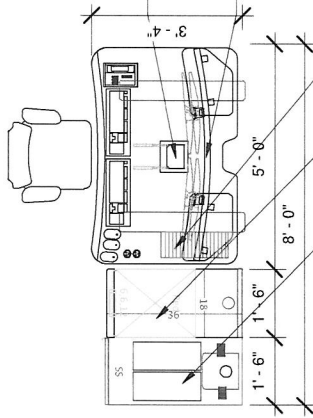

PANEL FABRIC	3D LAMINATE COUNTER	3D LAMINATE DRAWER/DOOR FRONT	MELAMINE	HANDLE
COLOR	COLOR	COLOR	COLOR	SILVER





CONCEPTUAL IMAGES. REFER TO ACTUAL COLOR SAMPLES FOR EXACT COLOR REPRESENTATION

FINISHES

① TYPICAL WORKSTATION
 3/8" = 1'-0"

MONITOR EXTENSION CABLE CONNECTIONS

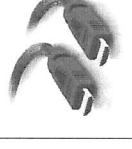
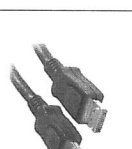
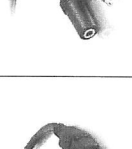
MONITOR EXTENSION CABLES PER POSITION Position Type TYPICAL WORKSTATION

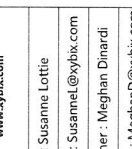
CABLE TYPE	DESCRIPTION	QTY. NEEDED
	VGA Male / Female Extension Standard connection for monitors	4 EA.
	DVI-D Male / Female Extension Typical for Hi-Resolution	
	DVI-I 10' Max Length Male / Female Extension Typical for Hi-Resolution	
	HDMI Male / Male Replacement Typical for Hi-Resolution	
	Display Port Male / Male Replacement Typical for Hi-Resolution	
	USB Keyboard Mouse	
	AUDIO Typical for Speakers	

DATA DOCK

For Keyboard, Mice and Phone connection. Data Dock USB Cables are exclusively sold through Xybix only.

Standard Data Dock System will include:

- (1) CAT6 coupler
- (4) Dual-USB Ports (8 ports total)

STANDARD SHOWN

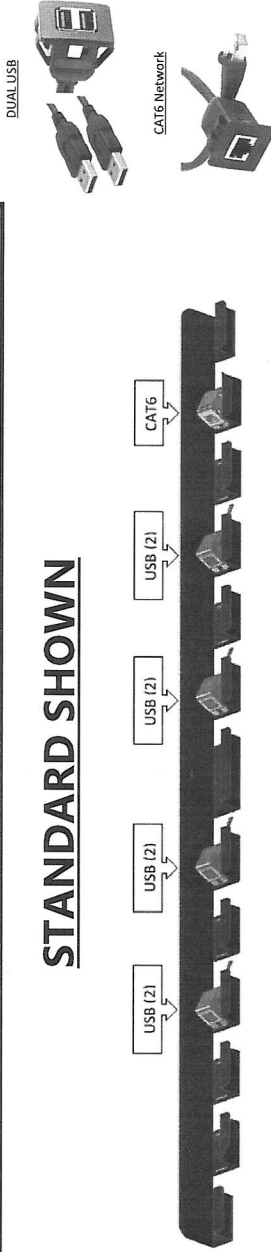

OPTIONAL ITEMS

ADDITIONAL DATA DOCK CABLES

Indicate the number of each cable to be included **in addition** to the standard Data Dock

NOTE: These cables will be charge separately

NOTE: There are only 5 available spaces for these options



QTY _____



QTY _____

If different cable connector types are required it is your responsibility to contact your designer or sales rep.

*** You agree that any changes to this order following receipt of sign-off drawing and PO may result in additional cost that will be expensed to the client ***

Signature: _____

Date: _____



8207 SouthPark Circle
Littleton, CO 80120
1.800.788.2610 F.303.683.5454
www.xybix.com

Sales : Susanne Lottie
Email : SusanneL@xybix.com
Designer : Meghan Dinardi
Email : MeghanD@xybix.com

York County EMA
149 Jordan Springs Rd
Alfred, ME 04002

Opportunity: 0025103
Drawing Name:
CABLE SHEET

SHEET: SCALE:
4 of 4

NOTE: This design & layout is the property of Xybix Systems, Inc. & is not to be used, copied, or reproduced in any manner without express written permission by Xybix Systems, Inc.

Sign-Off Initials: _____
REV 0

***SOUTHERN MAINE COMMUNICATIONS SERVICE
AIRPORT INDUSTRIAL PARK, 9 KOSTIS LANE
P.O. BOX 924
SANFORD, MAINE 04073***

VOICE (207) 324-6755 FAX (207) 324-6766

--ESTIMATE--

TO: Sanford Regional Communications
ATTN: Bill Tower
DATE: July 8, 2021
RE: Adding 3 backup radio console positions at YCEMA

--OVERVIEW--

Provide and install 3 new Zetron touchscreen radio consoles (same type as at SRCC to allow near identical operation) and common controller (server) along with associated control radios and antennas at YCEMA. This will be utilized to provide back-up communications for Berwick/South Berwick Police and Fire Channels, YCSO Primary channels, and YC Fire Primary channels. Customer to provide radio console furniture to allow placement of touchscreen and audio panel. Provide and install 2 multi-channel local control radios and connect radios to console system.

--MATERIALS--

9) Dispatch radio control base stations with RF filtering
on both TX and RX as required to prevent internal interference.

Radio channels are as listed:

(3) YCSO Primary channels

(2) BER/SB PD and Fire channels

(4) YC FIRE 1, 2, 3, watertank

@ 14,500.00 ea

\$ 130,500.00

2) Multi-channel radios near consoles (one VHF, one UHF)	@ 6,750.00 ea	\$ 13,500.00
9) Control radio antenna systems and lightning protection	@ 4,500.00 ea	\$ 40,500.00
2) Multi-channel radio antenna systems	@ 5,500.00 ea	\$ 11,000.00
1) Zetron Integrator RD consoles (3 positions) with M4020 control (complete Zetron materials list available upon request)		\$ 229,955.00

--INSTALLATION--

1) Installation and set-up of all listed materials at YCEMA		\$ 54,000.00
---	--	--------------

TOTAL AMOUNT: \$ 479,455.00

Best Regards,

Jeff Kostis

ZETRON CONSOLE PRICING FOR SRCC AT YCEMA 7-8-21

1) 905-0309 3 POSITION BUNDLE		\$ 141,720.00
3) 930-0026 EXTENDED PAGING	@ 1,369.00	4,107.00
3) 930-0051 MDC OPTION	@2,767.00	8,301.00
3) 930-0187 PAGING LICENSE	@2,304.00	6,912.00
3) 400-0205 AUDIO PANEL ENCLOSURE	@ 829.00	2,487.00
3) 950-1414 GOOSE NECK MIC	@ 827.00	2,481.00
3) 802-0092 M4217 PWR SUPPLY	@ 154.00	462.00
1) 950-9820 CHANNEL CARD		5,738.00
2) 950-0293 AUX/I-O RELAY CARD	@ 2,436.00	4,872.00
7) 950-9199 PROTECTED PUNCH BLOCKS	@ 1,019.00	7,133.00
9) 709-0004 25 PAIR CABLES	@ 107.00	963.00
3) 950-1270 19" TOUCHSCREEN	@ 1,589.00	4,767.00
2) 802-0330 RACK MOUNT UPS	@ 2,274.00	4,548.00
3) 802-0329 DESKTOP UPS	@ 412.00	1,236.00
3) 950-0083 19" EQUIP RACK	@ 3,076.00	9,228.00
1) MISC MATERIALS		25,000.00
	TOTAL ZETRON ONLY MATERIALS	\$ 229,955.00